

bernette
sublime

my
city

my
bernette



Rome 3
Rome 5
Rome 7

Instruction Manual
Instrucciones de manejo
Mode d'emploi
livro de instruções

EN Contents

Important Safety Instructions	1-2
Contents	10
Overview bernette Rome 3	14
Overview bernette Rome 5/7	16
Accessories bernette Rome 3	18
Accessories bernette Rome 5/7	20
Machine preparation	22-56
Needle, fabric, thread selection	58
Stitch selection	62
Standard sewing functions	76
Buttonholes	78-80
Enhanced sewing functions	82-120
Maintenance	122-126
Troubleshooting	128
Index	132

ES Índice

Normas de seguridad importantes	3-4
Índice	10
Vista general bernette Rome 3	15
Vista general bernette Rome 5/7	17
Accesorio bernette Rome 3	19
Accesorio bernette Rome 5/7	21
Preparación de la máquina	23-57
Tabla de aguja, tejido e hilo	59
Selección del punto	63
Funciones de costura estándar	77
Ojales	79-81
Funciones de costura avanzadas	83-121
Mantenimiento	123-127
Eliminar averías	129
Índice alfabético	133

Rome 3

EN Overview

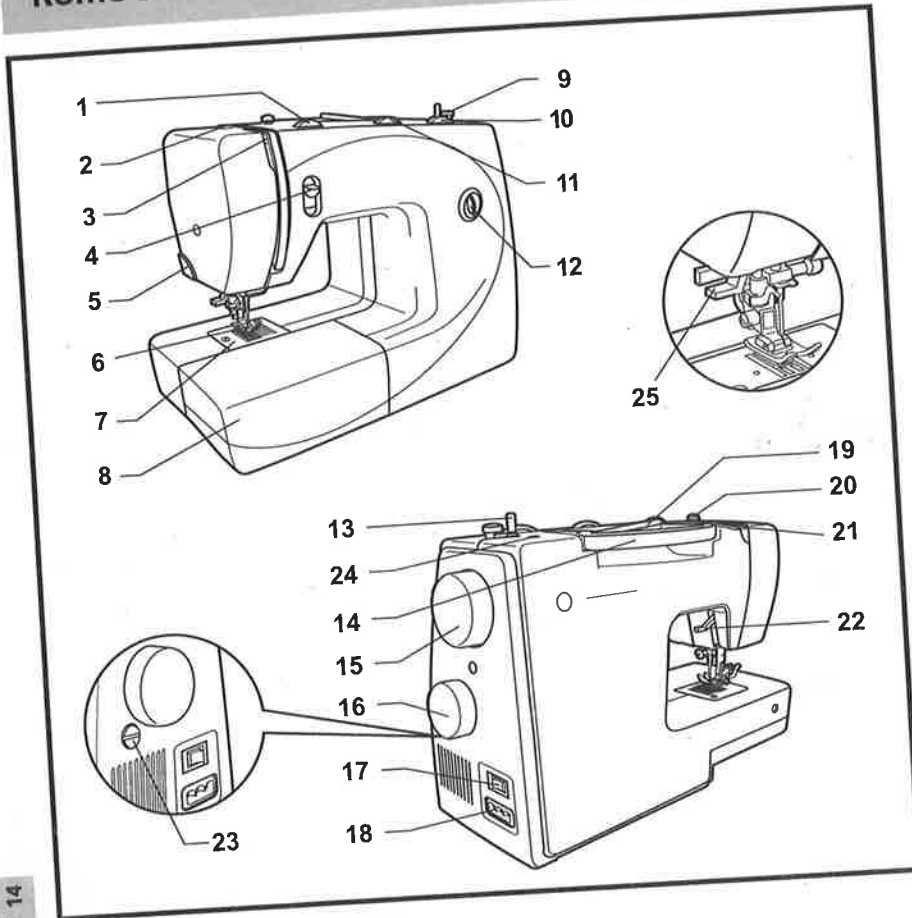

1. Thread tension dial
2. Presser foot pressure
3. Thread take-up lever
4. Reverse sewing lever
5. Thread cutting
6. Presser foot
7. Needle plate
8. Sewing table and accessory box
9. Bobbin stopper
10. Stitch length dial
11. Stitch width dial
12. Stitch display
13. Bobbin winder
14. Handle
15. Handwheel
16. Pattern selector dial
17. Power switch
18. Main plug socket
19. Spool pin
20. Bobbin thread guide/pre-tension
21. Upper thread guide
22. Presser foot lever
23. Pattern Balance
24. Hole for second spool pin
25. Automatic threader

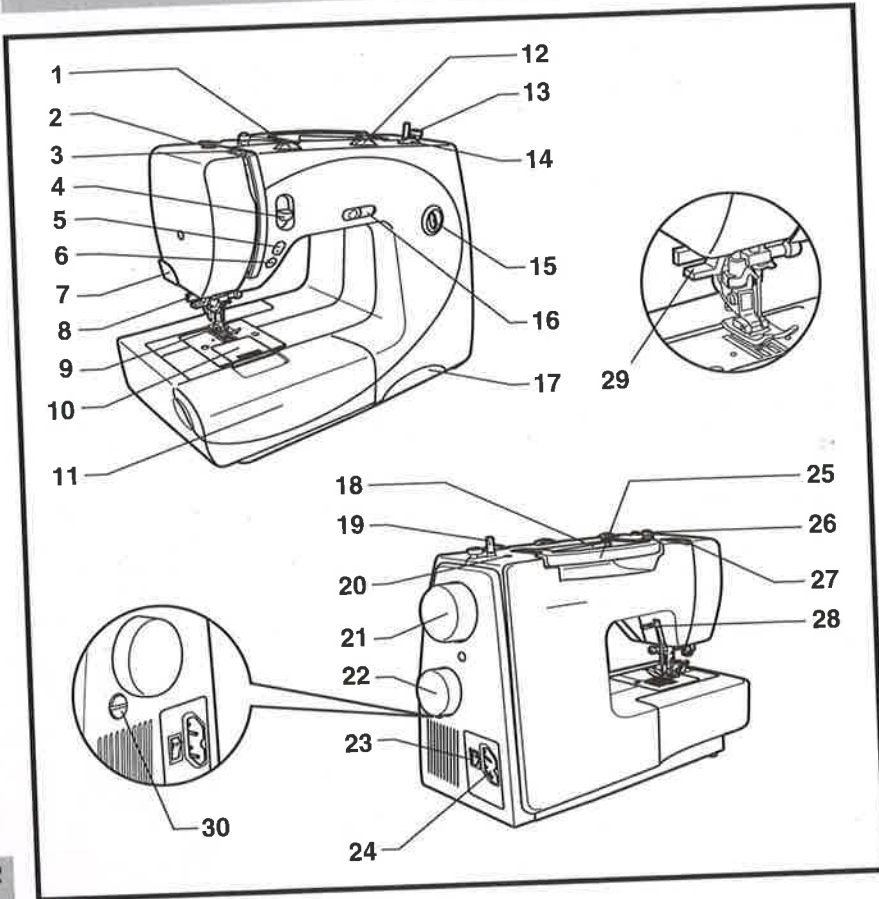

1. Tension dial
2. Presser foot pressure
3. Thread take up lever
4. Reverse sewing lever
5. Needle up / down position button (model Rome 7)* (LED)
6. Start-Stop-button (model Rome 7)*
7. Thread cutting
8. One step buttonhole lever
9. Presser foot
10. Needle plate
11. Sewing table and accessory box
12. Stitch width dial
13. Bobbin stopper
14. Stitch length dial
15. Stitch display
16. Speed limiting adjustment lever (model Rome 7)*
17. Quick reference drawer
18. Spool pin
19. Bobbin winder
20. Hole for second spool pin
21. Handwheel
22. Pattern selector dial
23. Power switch
24. Main plug socket
25. Handle
26. Bobbin thread guide/pre-tension
27. Upper thread guides
28. Presser foot lever
29. Automatic threader
30. Pattern Balance

*Equivelant Model only

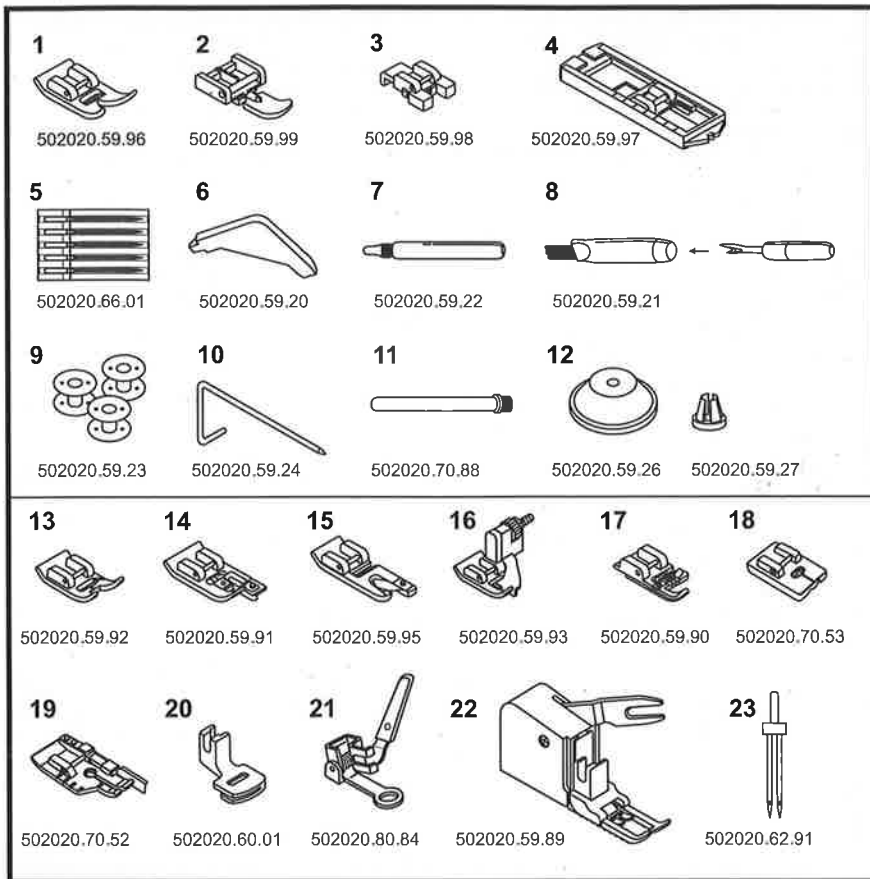

Standard accessories (1)

1. All purpose foot (J)
2. Zipper foot (I)
3. Button sewing foot
4. Buttonhole foot (B)
5. Pack of needles (5x)
6. L-screwdriver
7. Oil bottle
8. Seam ripper/ brush
9. Bobbin (3x)
10. Seam guide
11. Spool pin
12. Spool holder

Optional accessories *(2)

13. Satin stitch foot
14. Overcasting foot (G)
15. Hemmer foot
16. Blind hem foot (L)
17. Cording foot
18. Invisible Zipperfoot
19. Quilting foot 1/4"
20. Gathering foot
21. Darning/ Embroidery foot
22. Walking foot
23. Twin needle

* Optional accessories are not included. It must be bought separately.

Standard accessories (1)

1. All purpose foot (C)
2. Zipper foot (I)
3. Button sewing foot
4. Buttonhole foot (D)
5. Pack of needles (5x)
6. L-screwdriver
7. Seam ripper/ brush
8. Bobbin (3x)
9. Seam guide
10. Spool pin
11. Spool holder

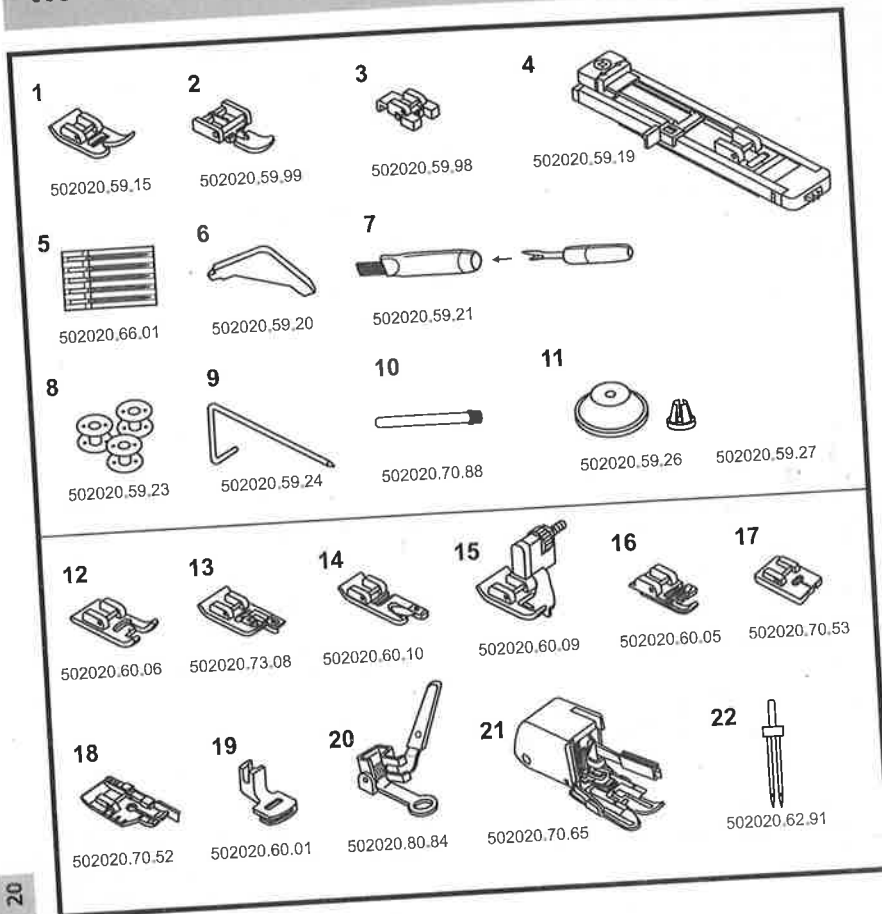

Optional accessories *(2)

12. Satin stitch foot (A)
13. Overcasting foot (E)
14. Hemmer foot (K)
15. Blind hem foot (F)
16. Cording foot (M)
17. Invisible Zipperfoot
18. Quilting foot 1/4"
19. Gathering foot
20. Darning/ Embroidery foot
21. Walking foot
22. Twin needle

* Optional accessories are not included. It must be bought separately.

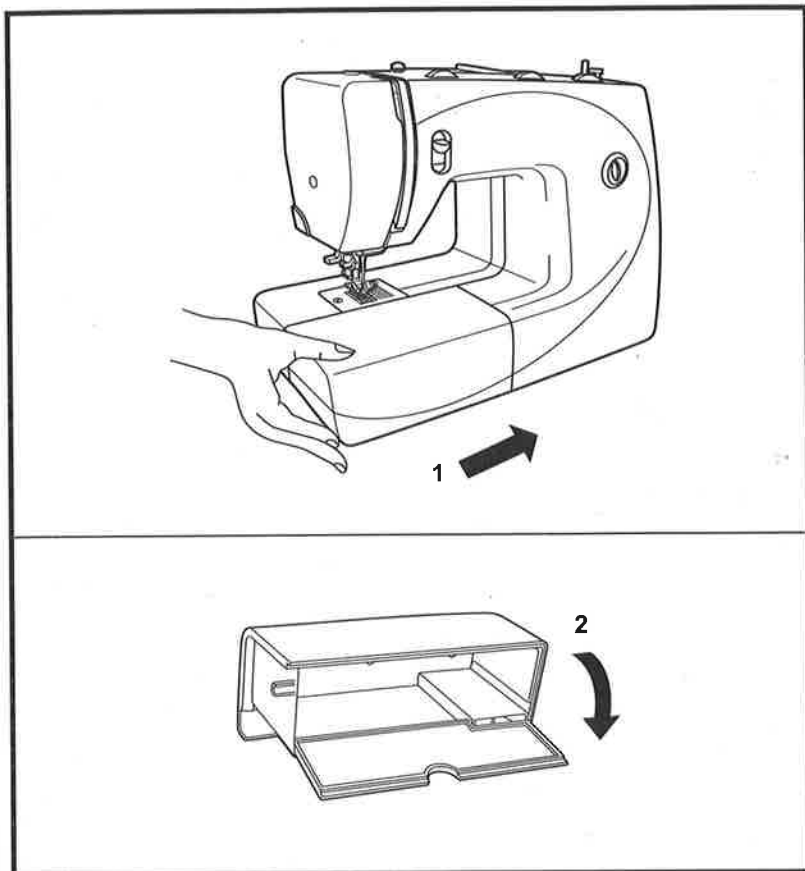

Hold the snap-in sewing table horizontal, and push it in the direction of the arrow. (1)

The inside of the snap-in sewing table can be utilized as an accessory box.

To open, tilt the cover towards you. (2)

EN Sewing table

Keep the snap-in sewing table horizontal, and push it in the direction of the arrow. (1)
 The inside of the snap-in sewing table can be utilized as an accessory box.
 To open, tilt the cover towards you. (2)

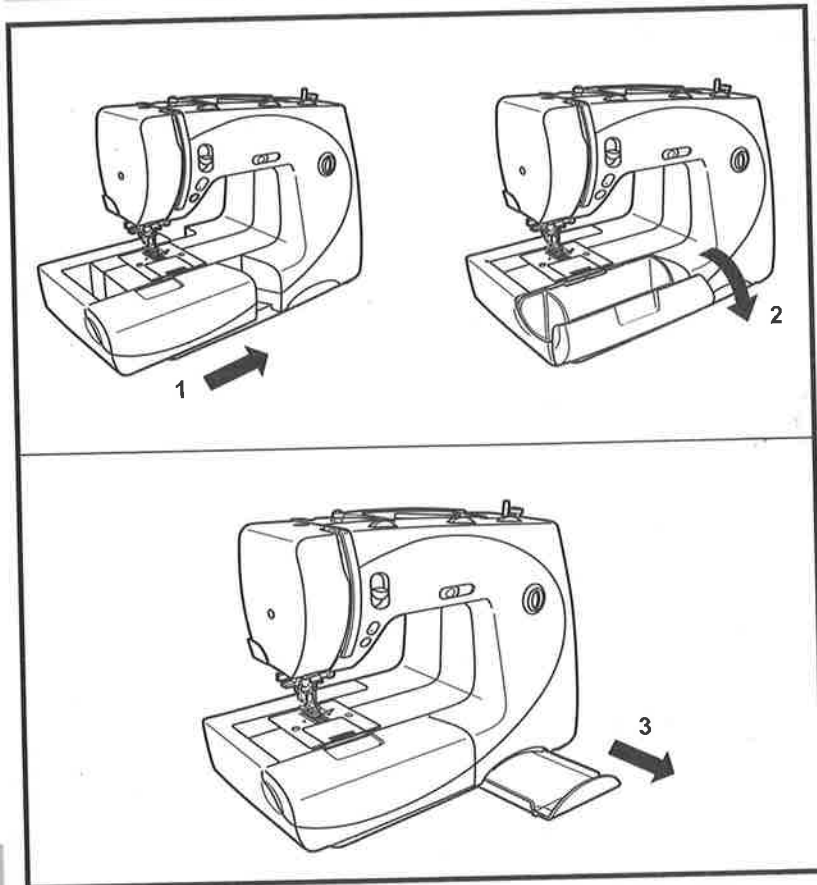

EN Quick reference drawer

To open pull the draw against you, to close push it back. The quick reference shows you recommended settings for the stitches and application. (3)

In this quick reference drawer you will find the most important information on sewing at a glance.
 The color coding of the stitches is the following:

- green (Practical Stitches) = Practical Stitches
- orange (Decorative Stitches) = Decorative Stitches
- blue (Stretch Stitches) = Stretch Stitches
- red (Quilt Stitches) = Quilt Stitches

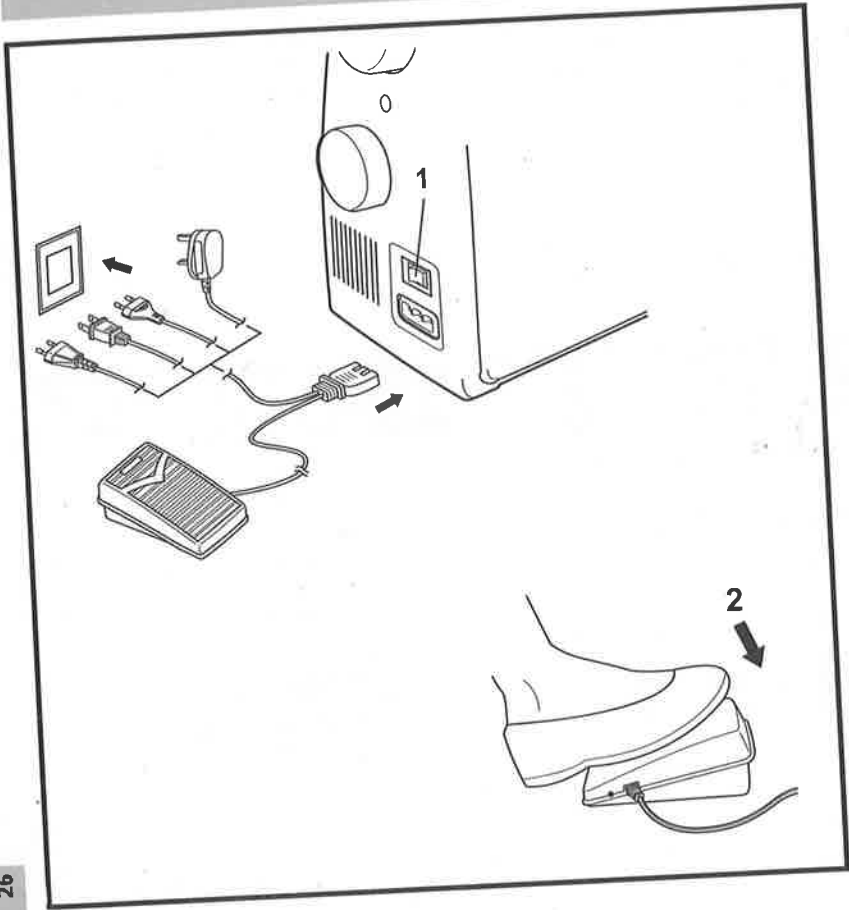

Connect the machine to a power source as illustrated.

Attention:
Unplug power cord when machine is not in use.

Sewing light
Press main switch for power and light on. (1)

Position 0 - Machine is switched off.
Position 1 - Machine and sewing light is switched on.

Foot control
Foot control regulates the sewing speed. (2)

Attention:
Consult a qualified electrician if in doubt as to connect machine to power source. Unplug power cord when machine is not in use. The appliance must be used with the foot controller KD-1902, FC-1902 (100-120V area), KD-2902, FC-2902D (220-240V area).

IMPORTANT NOTICE
If the appliance has a polarized plug (one blade is wider than the other). To reduce the risk of electric shock, this plug will fit in a polarized outlet only one way. If the plug does not fit fully in the outlet, reverse the plug. If it still does not fit, contact a qualified electrician. Do not modify the plug in any way.
The optimal operation temperature for the failure-free operation of this machine must be 68°F +/- 50°F.

Connect the machine to a power source as illustrated.

Attention:

Unplug power cord when machine is not in use.

Sewing light

Press main switch for power and light on. ("I")

Position 0 - Machine is switched off.

Position 1 - Machine and sewing light is switched on.

Foot control

Foot control regulates the sewing speed.

Attention:

Consult a qualified electrician if in doubt as to connect machine to power source. Unplug power cord when machine is not in use. The appliance must be used with the foot controller FC-9001, FC-9007, FC-9009 (220-240V area), FC-9005 (110-127V area) manufactured by ZHEJIANG FOUNDER MOTOR Co., Ltd. (China).

IMPORTANT NOTICE

If the appliance has a polarized plug (one blade is wider than the other). To reduce the risk of electric shock, this plug will fit in a polarized outlet only one way. If the plug does not fit fully in the outlet, reverse the plug. If it still does not fit, contact a qualified electrician. Do not modify the plug in any way.

The optimal operation temperature for the failure-free operation of this machine must be 68°F +/- 50°F.

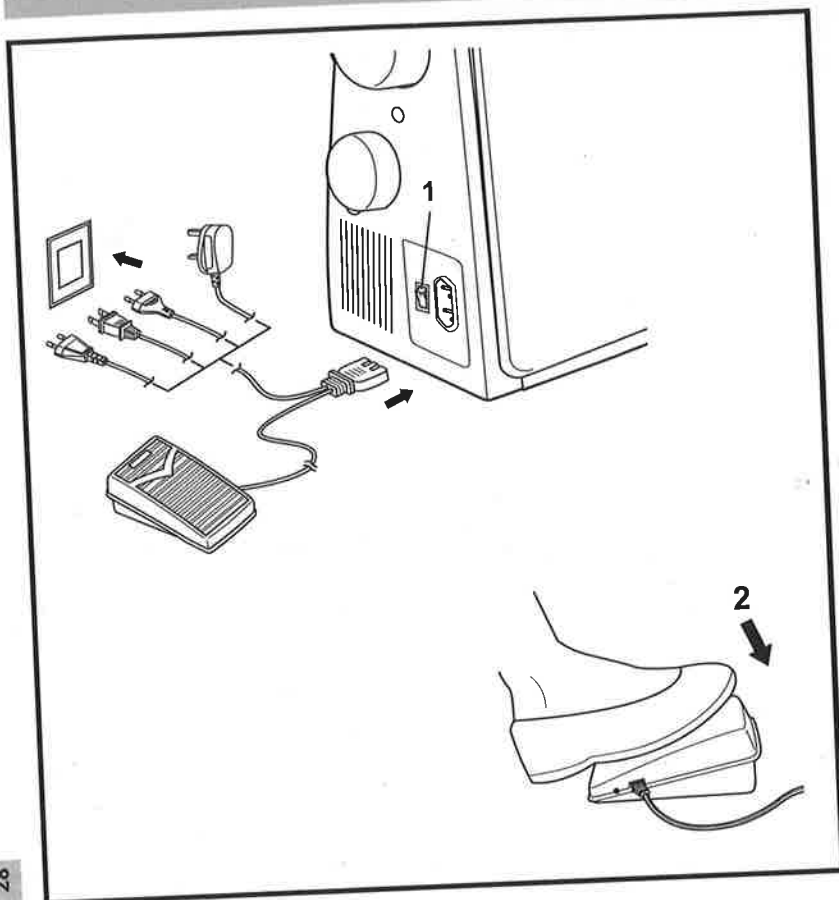

EN Two-step presser foot lever

When sewing several layers or thick fabrics, the presser foot can be raised to a second stage for easy positioning of the work.

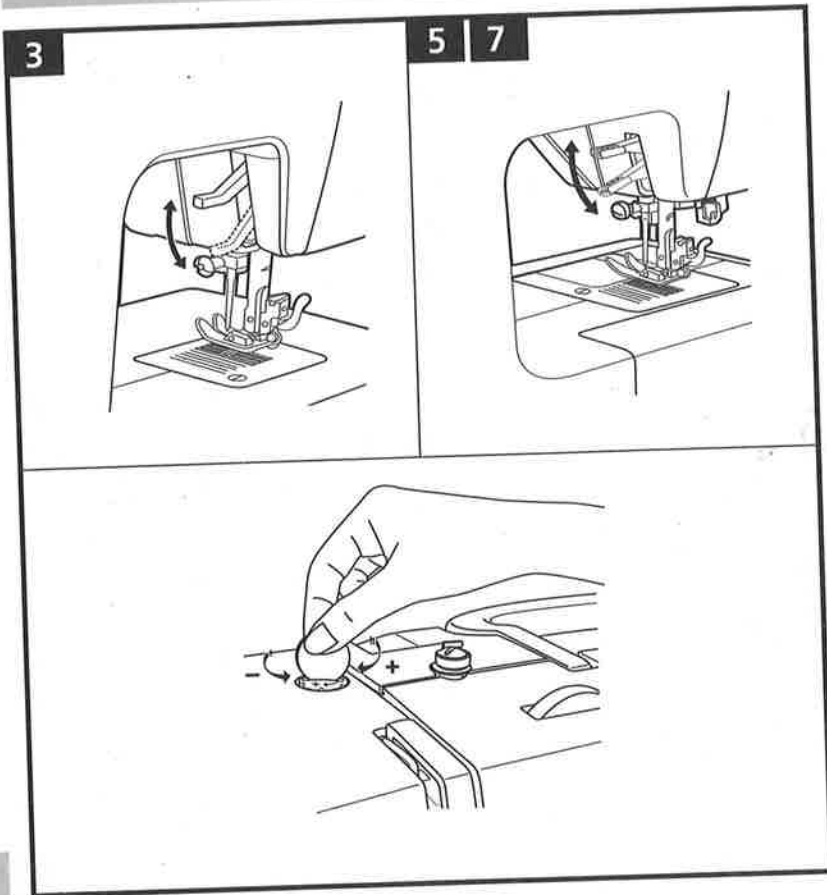

EN Adjusting the presser foot pressure

The presser foot pressure has been pre-set and requires no particular adjustment for regular sewing

However, it can be adj. according your needs

For sewing very thin fabric, loosen the pressure by turning the screw counter clockwise, and for heavy fabric, tighten by turning it clockwise.

Attention:

Turn power switch to "0" before carrying out any of the operations below.

Raise the needle to its highest position and raise the presser foot lever. Attach the presser foot holder (b) to the presser foot bar (a). (1) Tighten the fixation screw. (A)

Attaching the presser foot:

Lower the presser foot holder (b) until the cut-out (c) is directly above the pin (d). (2) Lower the presser foot holder (b) and the presser foot (f) will engage automatically.

Removing the presser foot:

Raise the presser foot. Release the pressure foot by raising lever (e) located at the back of the foot holder. (3)

Attaching the seam guide:

Attach the seam guide (g) in the slot as illustrated. Adjust the distance as required for hems, pleats, etc....(4)

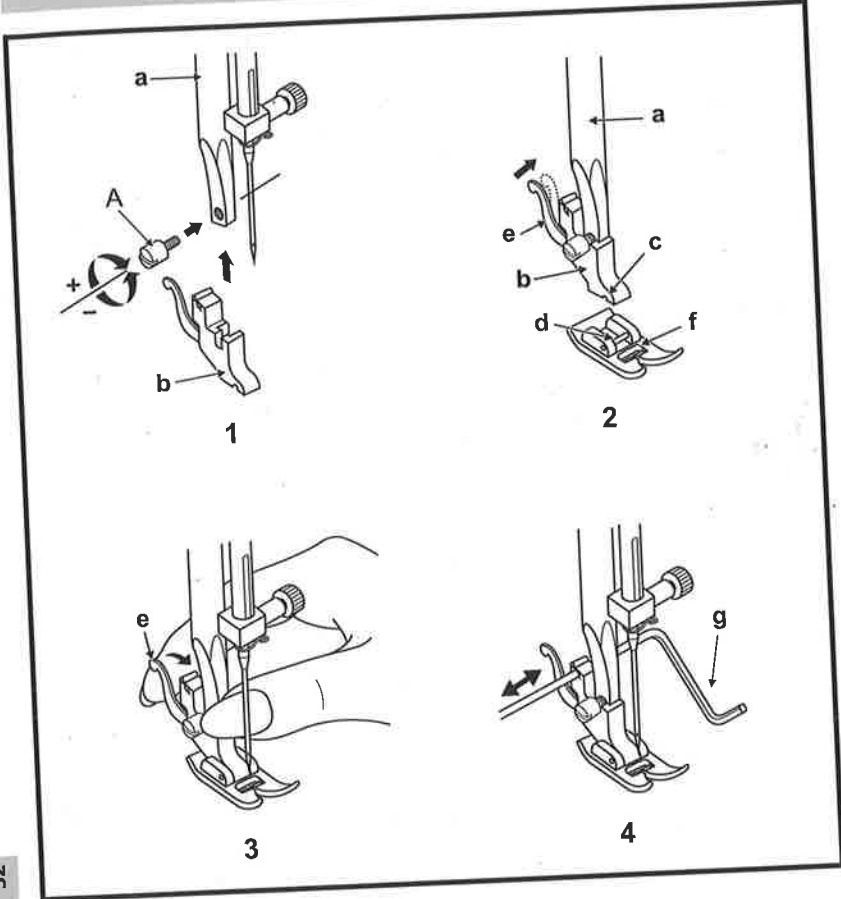

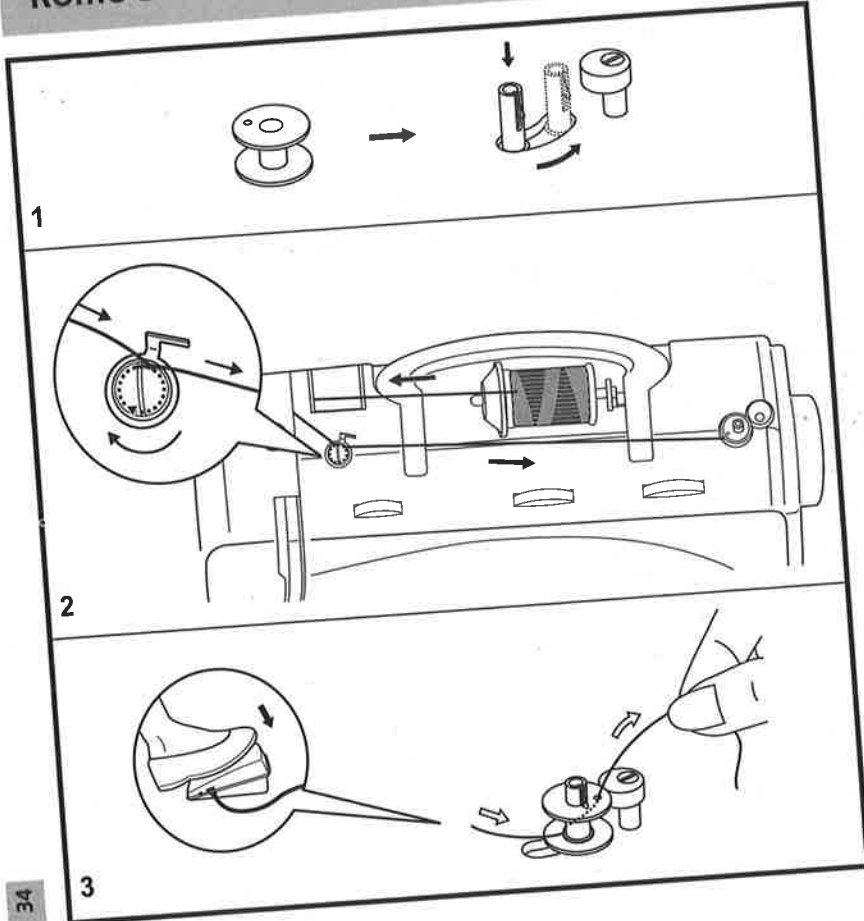

1. Place an empty bobbin on the spindle.
2. Guide the thread to the left, and pass it through the bobbin winder tension. Take the thread to the right till you reach the bobbin.
3. Wind the thread a few times by hand around the empty bobbin in a clockwise direction or pass the thread through one of the holes on the bobbin inside out and hold the thread. Push the bobbin to the right towards the bobbin winding position. Press the foot control gently. The bobbin will stop winding when it is full. Push the bobbin to the left to "sewing position" and remove it.

Please note:
 When the bobbin winder spindle is in "bobbin winding" position, the machine and the handwheel can not be operated. To start sewing, push the bobbin winder spindle to the left (sewing position).

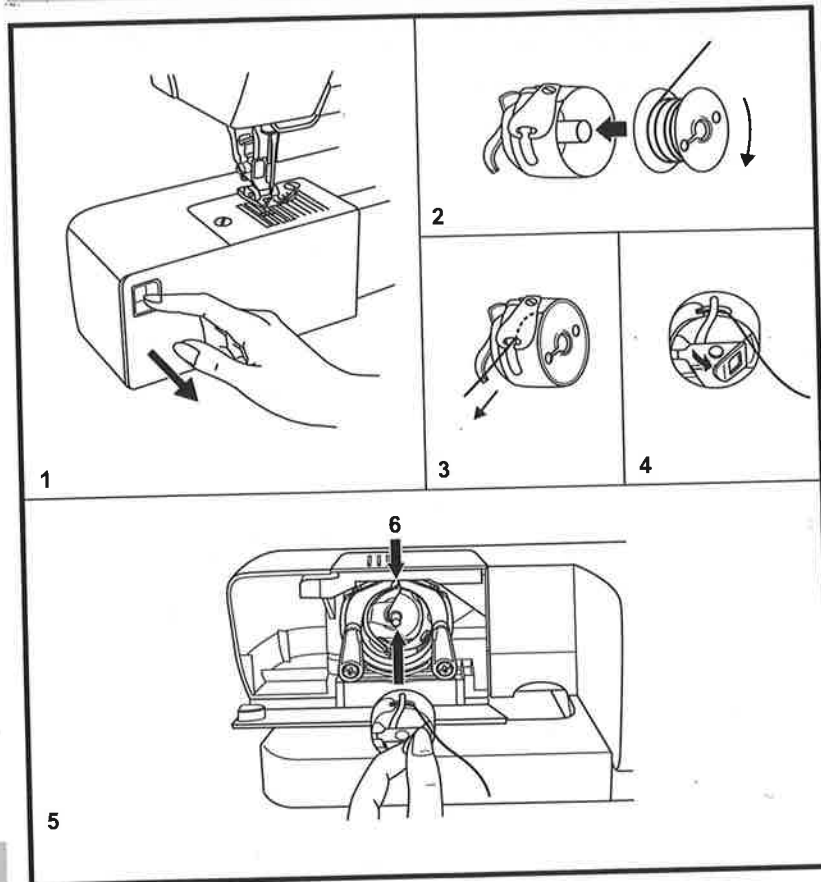

When inserting or removing the bobbin, the needle must be fully raised.

- Open the hinged cover (1).
- Remove the bobbin case by pulling its latch towards you and pulling it out from the hook.
- Hold the bobbin case with one hand. Insert the bobbin so that the thread runs in a clockwise direction (arrow) (2).
- Pull the thread through the slit and under the finger (3), spring
- Hold the bobbin case by the hinged latch (4).
- Insert it into the hook (5). Make sure the bobbin case finger fits into the notch (6) at the top of the race.

Attention:

Turn power switch to off ("O") before inserting or removing the bobbin.

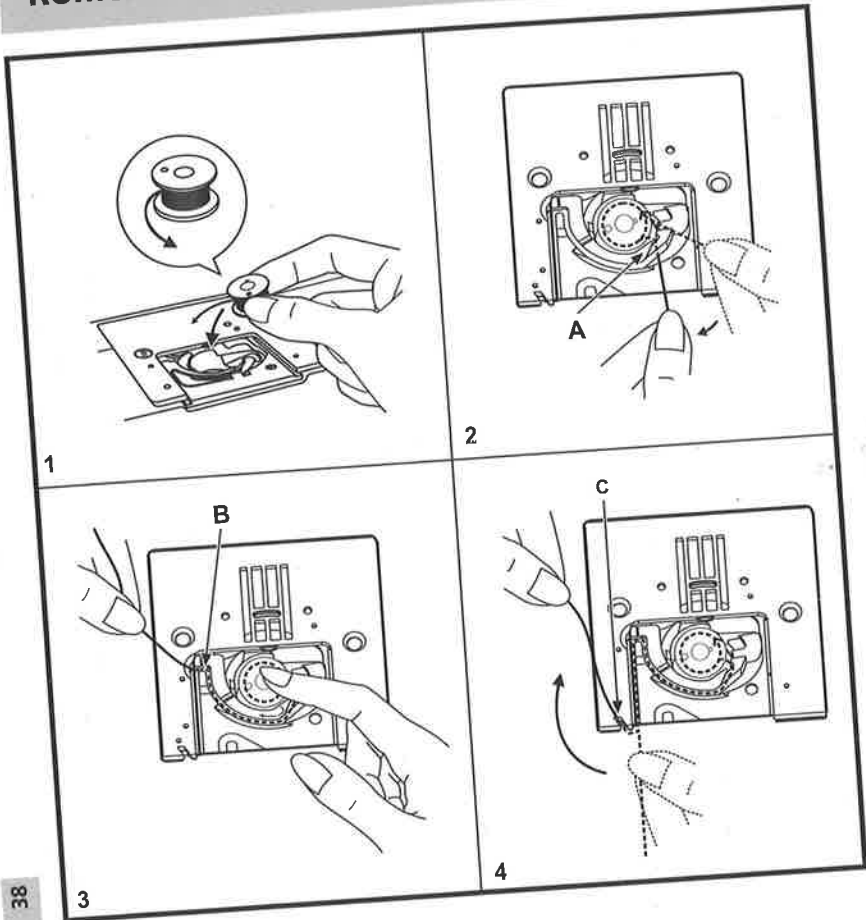

Caution:

- Turn power switch to "O" before threading or unthreading the machine.
- The thread take-up lever must be in the highest position when threading.
- **A wrong threading in can cause damages to the machine!**

To open the bobbin cover, slide it against you.

1. Inserting the bobbin in the bobbin holder with the thread running counter clockwise direction.
2. Pull the thread along the arrow marking through the slit under the finger (A) as far as the pulley (B).
3. To make sure that the thread is pulled into the tension spring of the bobbin holder, press a finger slightly onto the bobbin while pulling. As a check you must feel a resistance in the thread feed.
4. Pull the thread at the arrow markings into the stitch plate thread guide from (B) to (C).

To cut off excess thread pull thread back over the cutting off blade at point (C).

To close the bobbin cover, push it to the back.

Attention:
Turn power switch to "O" before inserting or removing the needle.

Change the needle regularly, especially if it is showing signs of wear and causing problems.

Insert the needle as illustrated:

- A. Loosen the needle clamp screw and tighten again after inserting the new needle. (1)
- B. The flat side of the shaft should be towards the back.
- C/D. Insert the needle as far up as it will go.

Needles must be in perfect condition. (2)

- Problems can occur with:
- A. Bent needles
 - B. Blunt needles
 - C. Damaged points

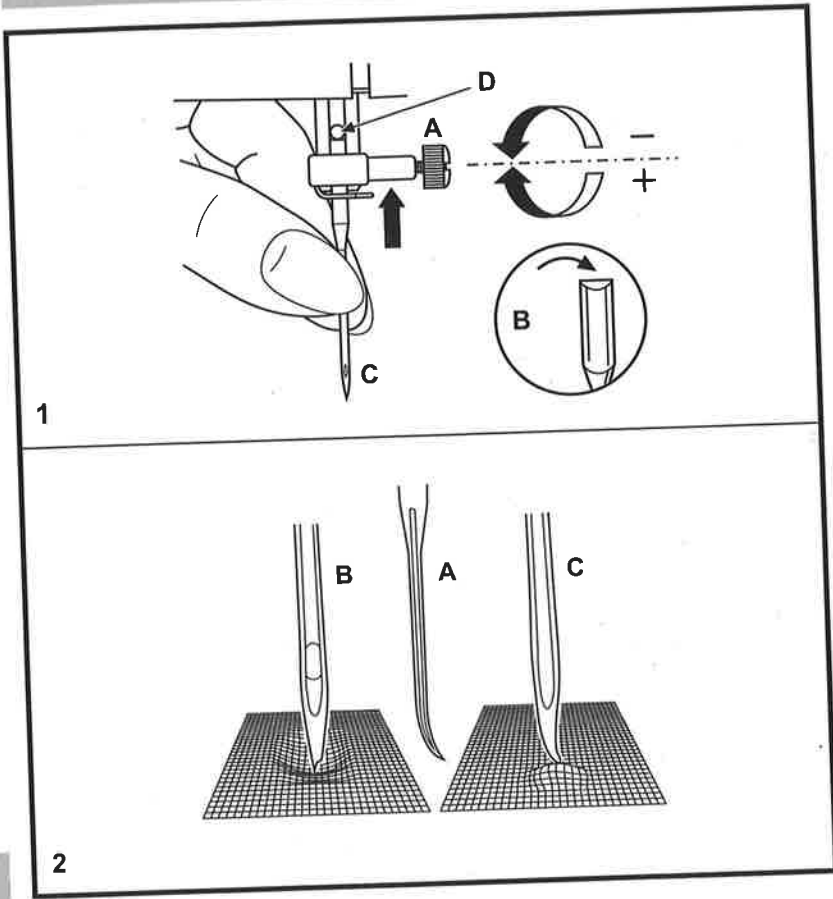

Caution:

- Turn power switch to "O" before threading or unthreading the machine.
- To release the upper thread tension the presser foot lever has to be raised.
- The thread take-up lever must be in the highest position when threading.

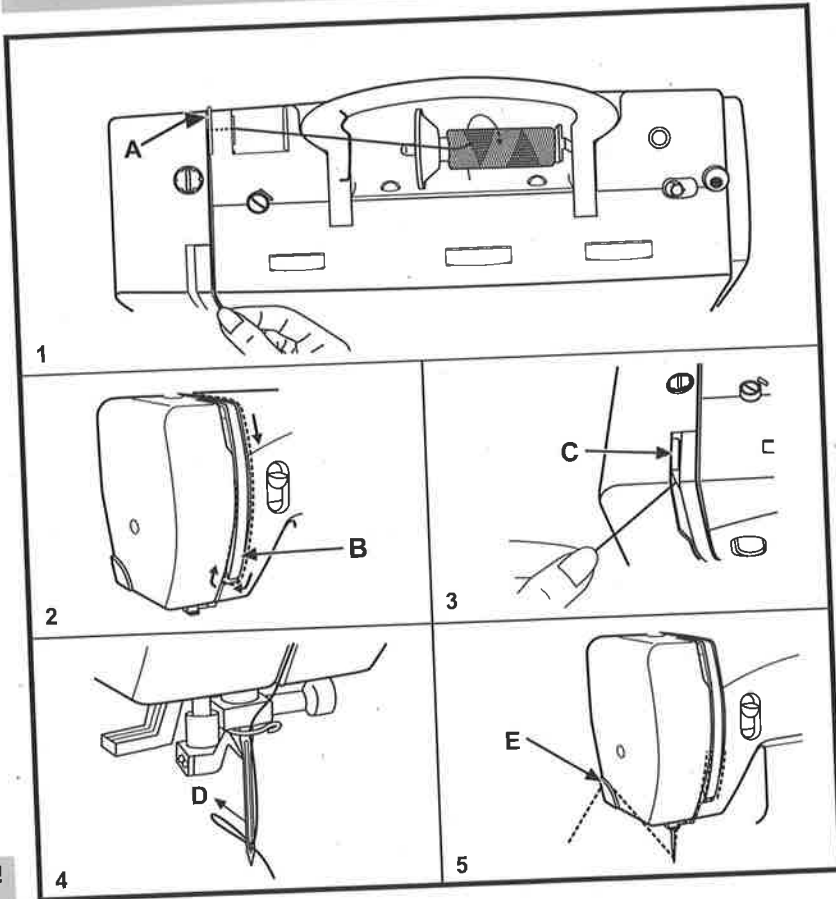

1. Place spool on pin using appropriate spool disc (spool turns clockwise). Take thread through rear guide (A) and then into slit of upper thread tension.
2. Pull thread down to the right of the cover around point (B)
3. Take thread up to the left of the cover, placing it in the take-up lever (C)
4. Take thread down and through guide (D). Insert the thread through the eye of the needle from front to back. (needle threader page 40)
5. Leave about 10 cm (4") of thread loose behind the needle, or cut the excess thread by using the thread cutter (E)

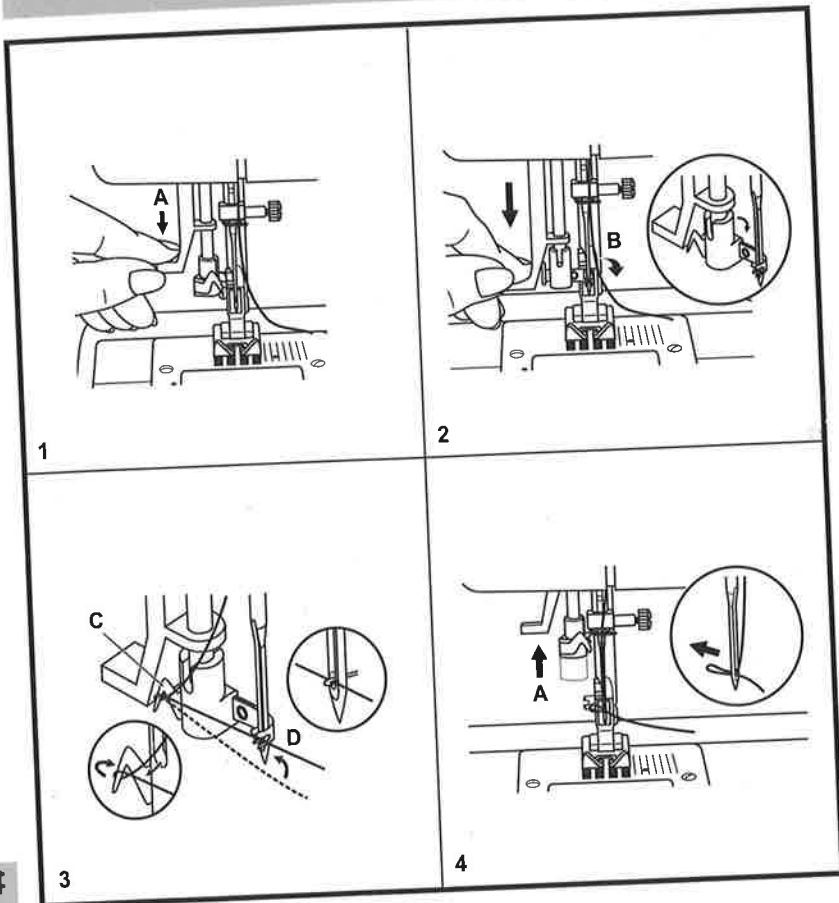

- Raise the needle to its highest position
- Press lever (A) right down
- The threader automatically swings to the threading position (B)
- Take the thread round the hook (C)
- Take the thread in front of the needle so that the thread will insert into the hook (D) from bottom to top
- Release lever (A)
- Pull the thread through the needle eye.

Attention:
Turn power switch to "0"!

Basic thread tension setting: "4". To increase the tension, turn the dial to the next number up. To reduce the tension, turn the dial to the next number down.

- A. Normal upper thread tension (A1)
- B. The upper thread tension is too loose, increase setting (C1)
- C. The upper thread tension is too tight, decrease setting (B1)

Note:
The tension is factory set for best possible sewing results using a thread (Metrosene 100/2). The optimum tension may vary when using other or different types of thread, and it may be necessary to adjust tension to suit the fabric and stitch type.

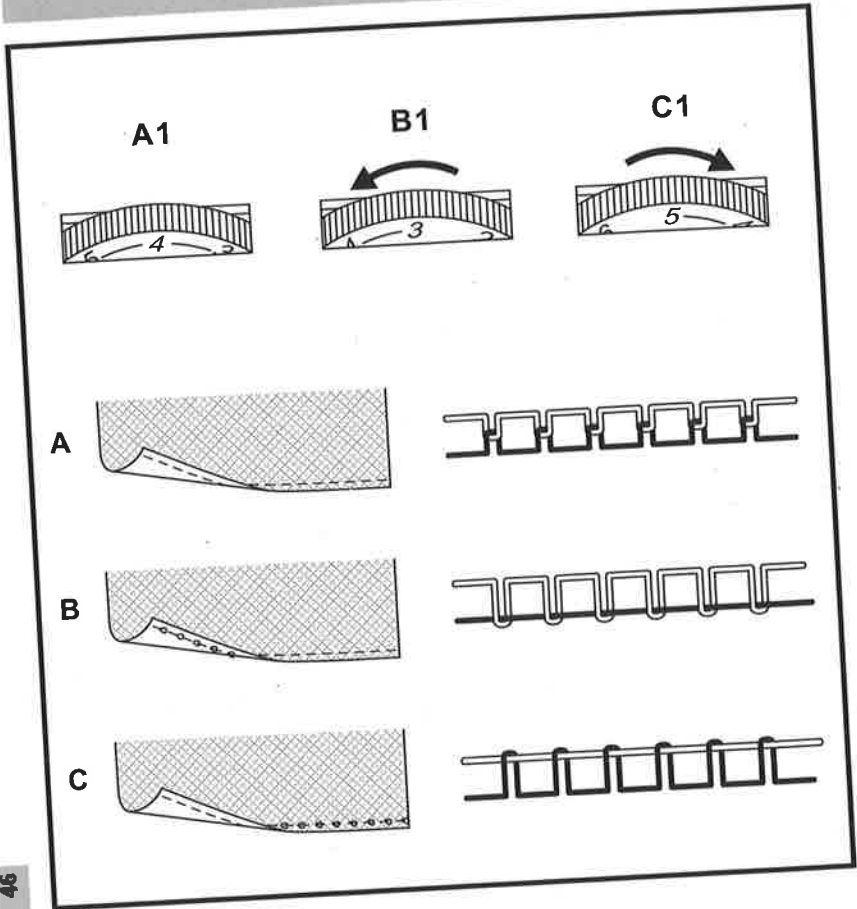

EN Bringing up the lower thread

Hold the upper thread with the left hand. Turn the handwheel forward until the needle is raised, (1) again.

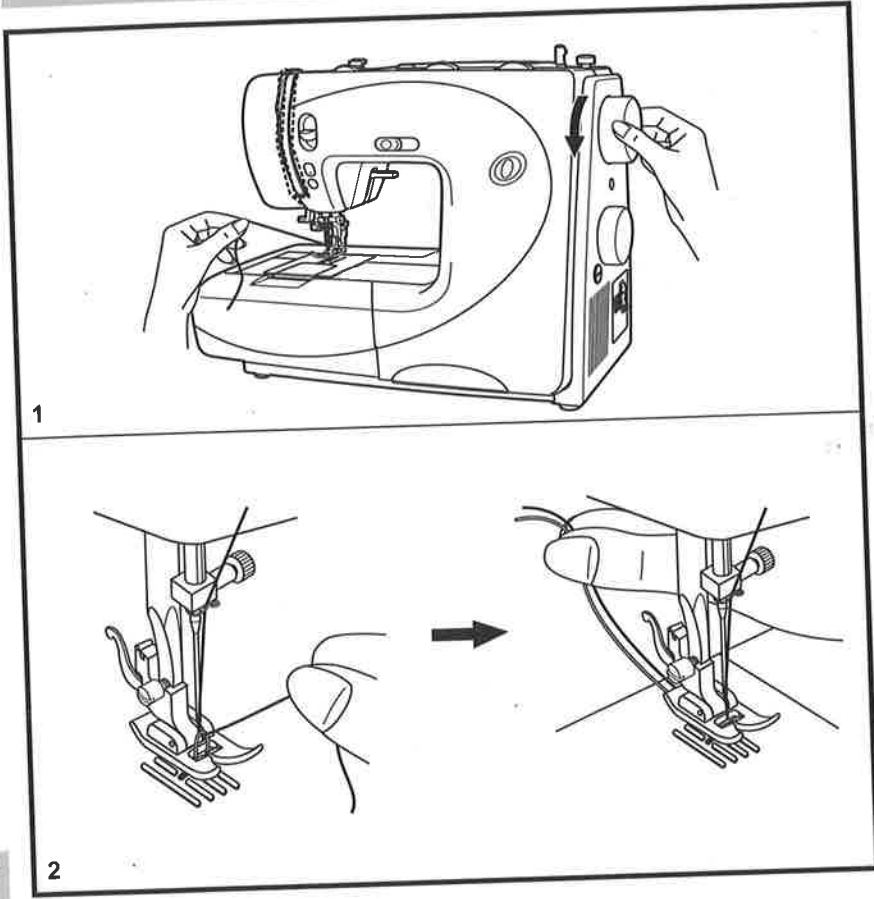

Pull on the upper thread to bring the lower thread up through the stitch plate hole. Lay both threads to the back under the presser foot. (2)

Note:
When the excess thread was cut, the thread can be brought up, however does not have to.

Caution:
When starting to sew do not pull on the taut threads under the presser foot.

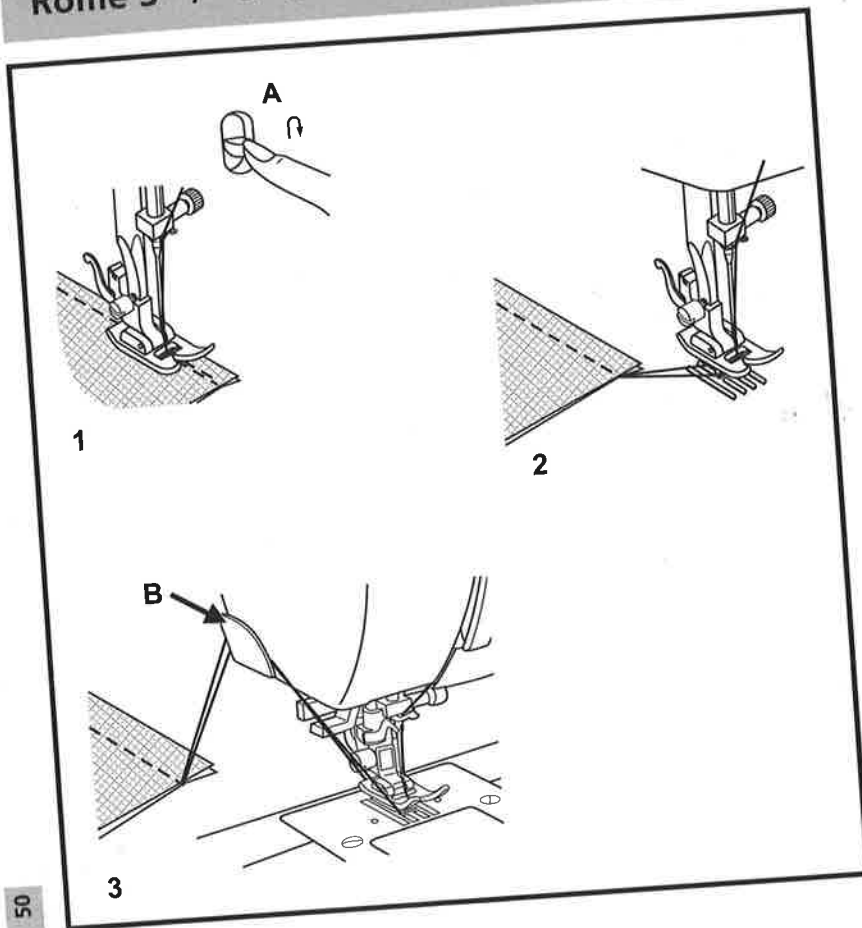
**Beginning the seam**

Place fabric approximately 1cm (1/2") inward from the outer edge under the presser foot. Press the Quick Reverse button (A) while sewing backwards up to the fabric edge. Release the Quick Reverse button and continue sewing.

End of seam (1)

At the end of seam, press down the reverse sewing lever (A). Sew a few reverse stitches. Release the lever and the machine will sew forwards again.

Removing the work (2)

Turn the handwheel towards to bring the thread take up lever to its highest position, raise the presser foot and remove the work towards the back. On model Rome 7 the thread take up lever automatically stops in the correct position by pressing the needle up/down position button.

Cutting the thread (3)

Cut both threads with the thread cutter (B) located on the left rear side of the face plate.

3

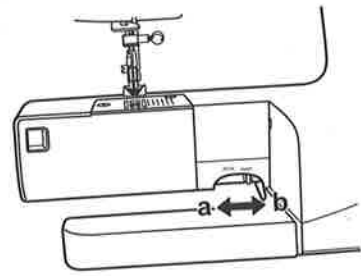

5 | 7

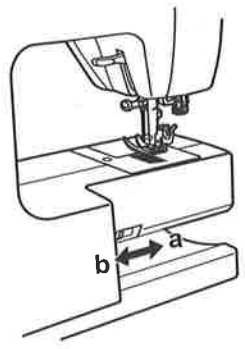

For ordinary sewing, keep the feed dog up, for freehand embroidery, sewing on buttons and darning, drop the feed dog. To raise (a) and lower (b) feed dog.

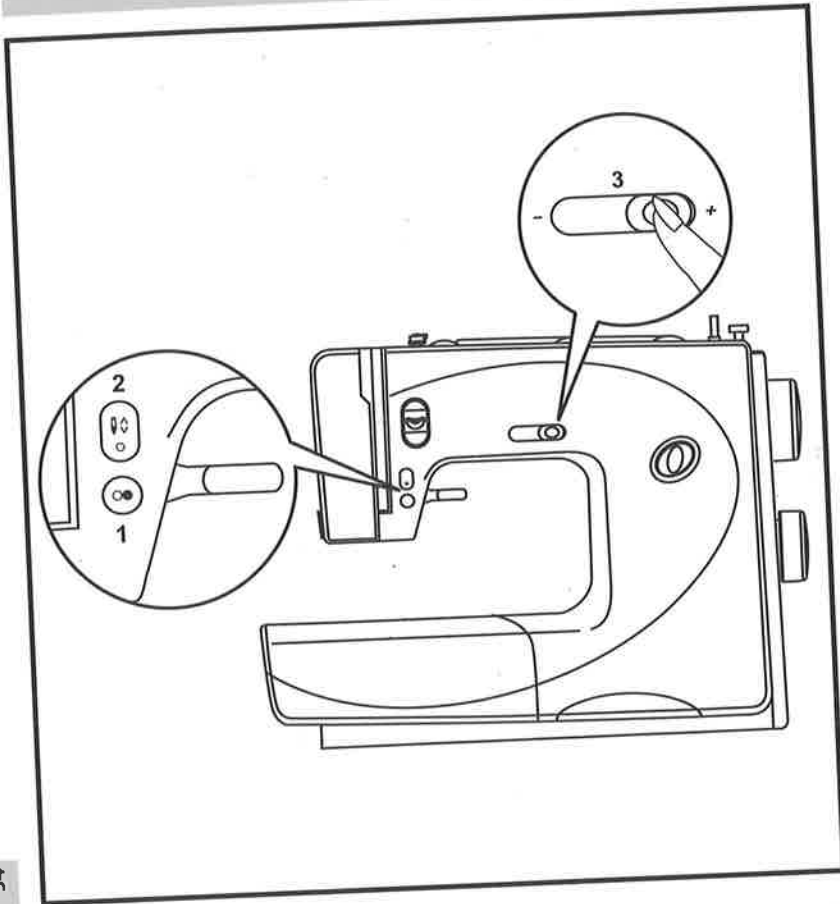

EN Start Stop Button

Press the Start/Stop Button (1) to start the machine. Press again to stop it. This way you may operate the machine without foot control.

EN Needle up/down

Before sewing press the button needle up/down (2). (LED illuminated when needle position down is activated). The stop position of the needle is predetermined by this button. Press the button twice to perform one full stitch.

EN Speed limiting adjustment

Slide the lever to the left or right to change the sewing speed. (3)

The machine can be sewed faster when the lever is moved to the right, and sew slower when lever is moved to the left.

Toward - slower
Toward + faster

If the decorative stitch patterns or buttonhole are uneven when sewing with particular fabrics, turn the feed balancing dial* with a coin or a screwdriver for adjustment.

* This dial should be in a neutral position. (1)

Adjusting distorted stretch stitch patterns

If the patterns are too open, turn the dial counterclockwise. (2) "-"

If the patterns are too close, turn the dial clockwise. (2) "+"

Adjusting the stitch density of buttonhole

If the stitches on the right side of the buttonhole are too open, turn the dial counterclockwise. (3) "-"

If the stitches on the right side of the buttonhole are too close, turn the dial clockwise. (3) "+"

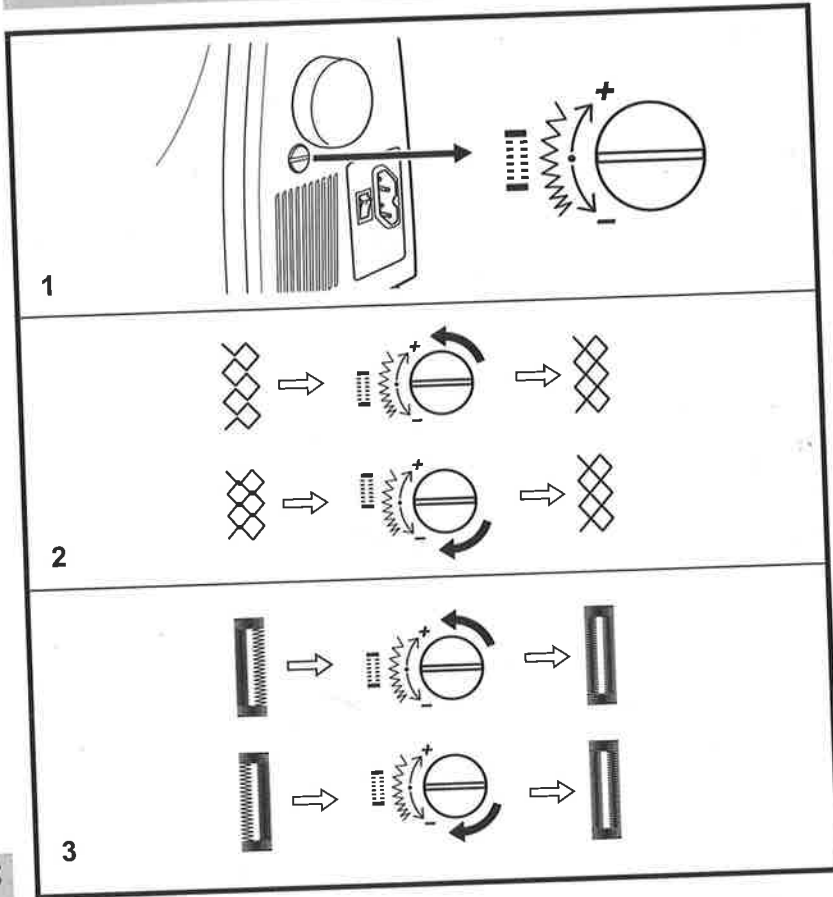

NEEDLE SIZE	FABRICS	THREAD
9-11/65-75	Lightweight fabrics-thin cottons, voile, serge, silk, muslin, Qiana, interlocks, cotton knits, tricot, jerseys, crepes, woven polyester, shirt & blouse fabrics.	Light-duty thread in cotton, nylon or polyester.
12/80	Medium weight fabrics-cotton, satin, kettlecloth, sailcloth, double knits, lightweight woollens.	Most threads sold are medium size and suitable for these fabrics and needle sizes. Use polyester threads on synthetic materials and cotton on natural woven fabrics for best results. Always use the same thread on top and bottom.
14/90	Medium weight fabrics-cotton duck, woolen, heavier knits, terrycloth, denims.	
16/100	Heavyweight fabrics-canvas, woollens, outdoor tent and quilted fabrics, denims, upholstery material (light to medium).	
18/110	Heavy woollens, overcoat fabrics, upholstery fabrics, some leathers and vinyls.	Heavy duty thread, carpet thread. (Use heavy foot pressure-large numbers.)

IMPORTANT: Match needle size to thread size and weight of fabric

NEEDLE, FABRIC SELECTION

NEEDLES	EXPLANATION	TYPE OF FABRIC
HAX1 15x1	Standard sharp needles. Sizes range thin to large. 9 (65) to 18 (110)	Natural woven fabrics-wool, cotton, silk, etc. Qiana. Not recommended for double knits.
15x1/ 130/705H	Semi-ball point needle, scarfed, 9 (65) to 18 (110)	Natural and synthetic woven fabrics, polyester blends. Knits-polyesters, interlocks, tricot, single and double knits. Can be used instead of 15x1 for sewing all fabrics.
15x1/ 130/705H (SUK)	Full ball point needle 9 (65) to 18 (110)	Sweater knits, Lycra, swimsuit fabric, elastic.
130PCL/ 705H-LR/LL	Leather needles. 12 (80) to 18 (110)	Leather, vinyl, upholstery. (Leaves smaller hole than standard large needle.)

Note:

1. Twin needles can be purchased for utility and decorative work.
2. When sewing with twin needles, the stitch width dial should be set less than "2.5" (model Rome 3), "4" (model Rome 5/7).
3. European needles show sizes 65, 70, 80 etc. American and Japanese needles show size 9, 11, 12 etc.
4. Replace needle often (approximately every other garment) and / or at first thread breakage or skipped stitches.

3

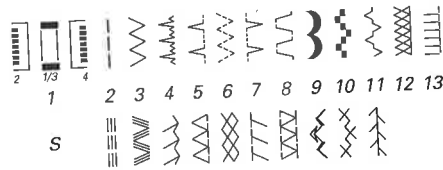
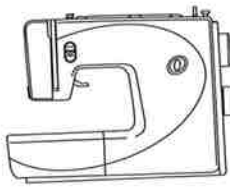

For straight stitch select pattern "1" with pattern selector dial. Adjust the stitch length with the stitch length dial. You may choose any needle position from center to left, by turning the stitch width dial.

For zigzag stitch, select pattern "2" with pattern selector dial. Adjust the stitch length and stitch width according to the fabric being used.

To obtain any of the other patterns shown in the upper row on the stitch selection panel, select the pattern with the pattern selector dial. Adjust the stitch length and the stitch width with the control dials according to the result desired. (see Quick reference draw)

To obtain any of the patterns on the second row, turn the stitch length dial to "S", select the pattern desired with pattern selector dial, and adjust the stitch width with the stitch width dial. To switch to "Position S", turn the stitch length knob to the 0, continue turning the knob in the same direction.

Note:
Between the positions "0" and "S", a bit of resistance is to be expected.

5

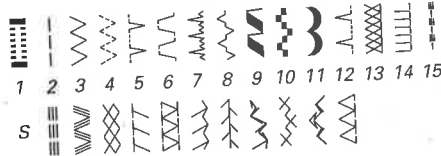
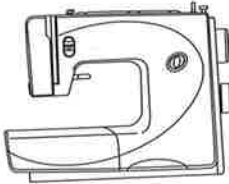

7

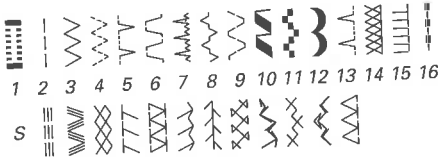
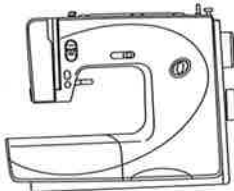

Function of stitch length dial Straight stitching

Turn the pattern selector dial so that the stitch display shows the straight stitch position.

The stitch length is controlled with the stitch length dial. While "2" - "3" on the dial gives a suitable stitch length for ordinary purposes.

Generally speaking the finer the fabric the finer the thread and shorter the stitch length, the heavier the fabric the thicker the thread and longer the stitch length.

At stitch length "0" the fabric will not move and the needle will keep piercing at the same point.

Choose your needle position, from center position to left needle position by changing the stitch width dial.

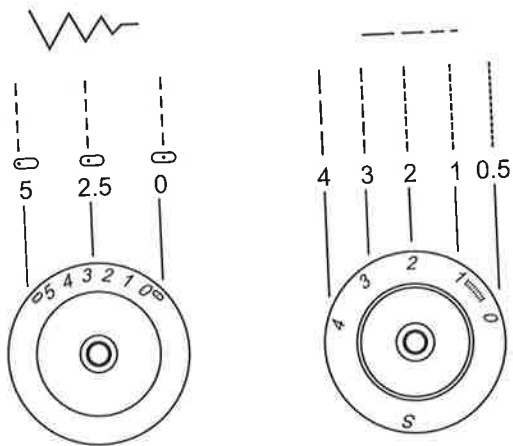
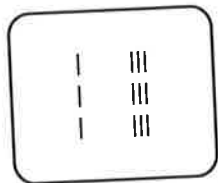

Function of stitch length dial Straight stitching

Turn the pattern selector dial so that the stitch display shows the straight stitch position.

The stitch length is controlled with the stitch length dial. While "2" - "3" on the dial gives a suitable stitch length for ordinary purposes.

Generally speaking the finer the fabric the finer the thread and shorter the stitch length, the heavier the fabric the thicker the thread and longer the stitch length.

At stitch length "0" the fabric will not move and the needle will keep piercing at the same point.

Choose your needle position, from center position to left needle position by changing the stitch width dial.

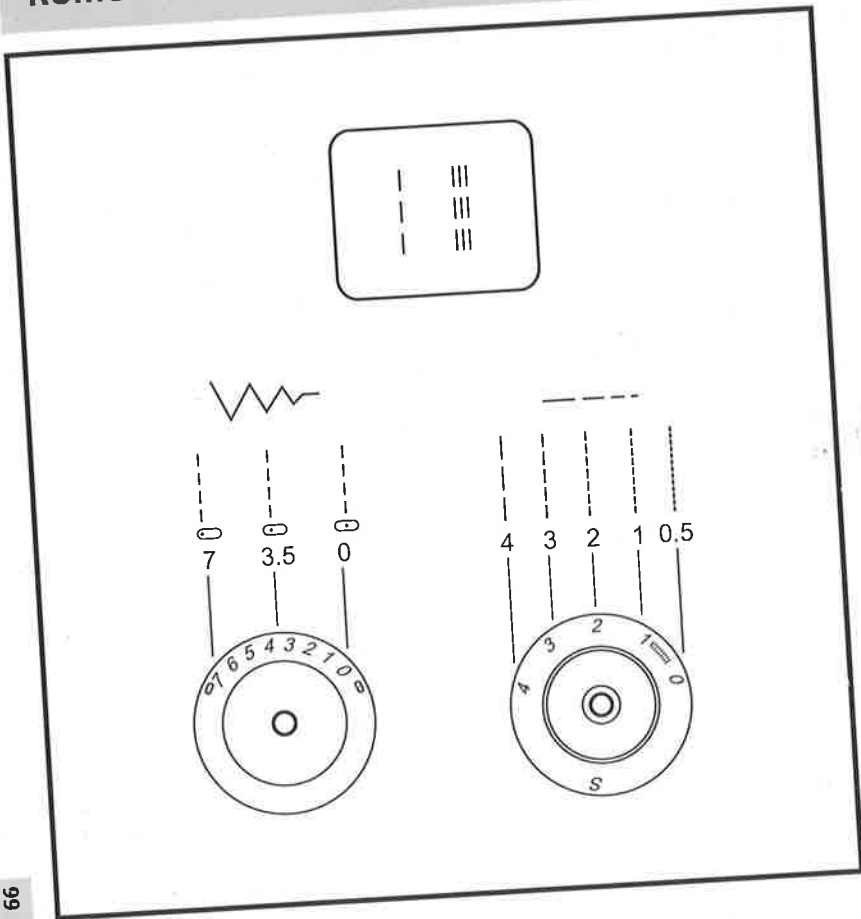

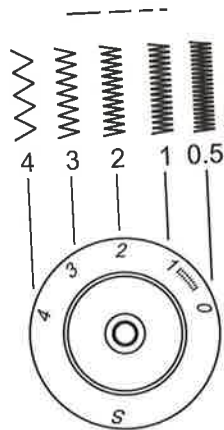
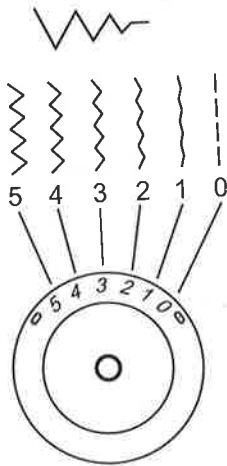
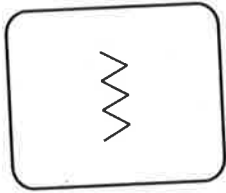

Function of stitch width dial

The maximum zigzag stitch width for zigzag stitching is "5"; however, the width can be reduced on any patterns. The width increases as you move zigzag dial from "0" - "5". For twin needle sewing, never set the width wider than "2.5". (model Rome 3)

Function of stitch length dial while zigzagging

The density of zigzag stitches increase as the setting of stitch length dial approaches "0". Neat zigzag stitches are usually achieved at "2.5" or below.

Satin stitch

When the stitch length is set between "0" - "1", the stitches are very close together producing the "satin stitch" which is used for making buttonholes and decorative stitches.

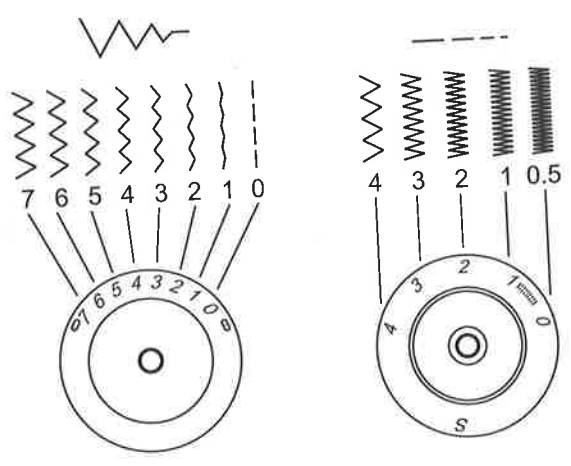
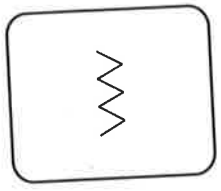

Function of stitch width dial

The maximum zigzag stitch width for zigzag stitching is "7"; however, the width can be reduced on any patterns. The width increases as you move zigzag dial from "0" - "7". For twin needle sewing, never set the width wider than "4". (model Rome 5/7)

Function of stitch length dial while zigzagging

The density of zigzag stitches increase as the setting of stitch length dial approaches "0". Neat zigzag stitches are usually achieved at "2.5" or below.

Satin stitch

When the stitch length is set between "0" - "1", the stitches are very close together producing the "satin stitch" which is used for making buttonholes and decorative stitches.

Presser foot available as optional accessory
 For hems, curtains, trousers, skirts, etc.

▲▲▲ Blind hem/lingerie for firm fabrics.
 ▲▲▲▲ Blind hem for stretch fabrics.
 Set the machine as illustrated.

Note:
 It takes practice to sew blind hems. Always
 make a sewing test first.

Fold the fabric as illustrated with the wrong
 side uppermost. (1)
 Place the fabric under the foot. Turn the
 handwheel forward by hand until the
 needle swings fully to the left. It should
 just pierce the fold of the fabric. If it does
 not, adjust the stitch width accordingly. (2)
 Adjust the guide (3) by turning the knob
 (4) so that the guide just rests against the
 fold. Sew slowly, by pressing the foot
 control lightly, guiding the fabric along the
 edge of the guide.

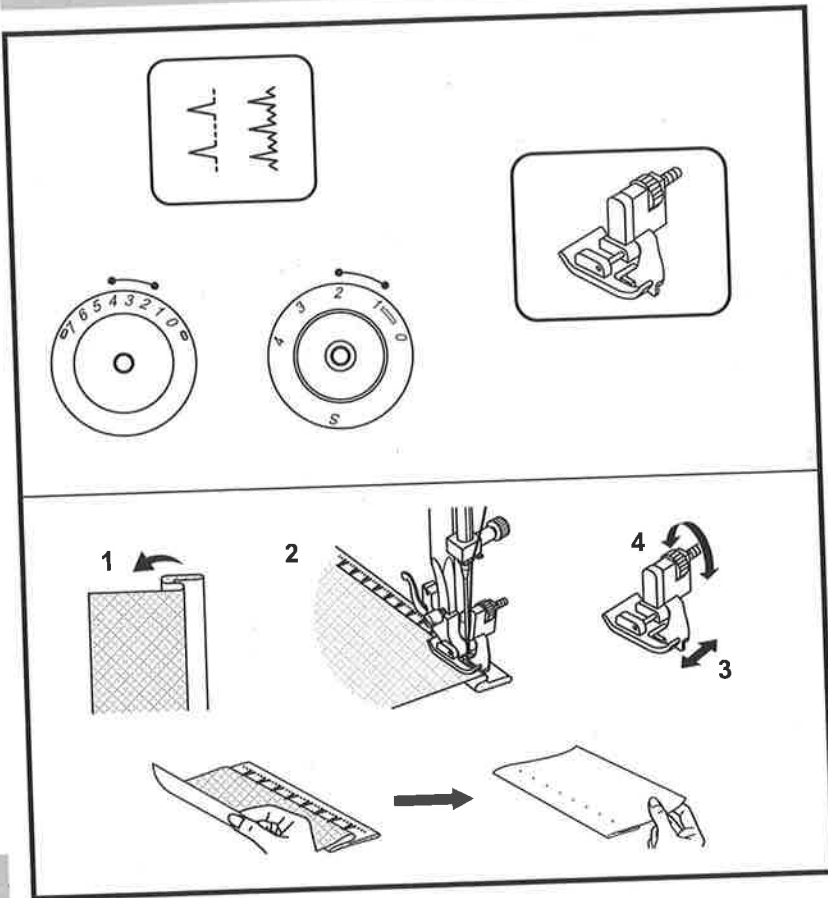

Presser foot available as optional accessory

Seams, neatening, visible hems.
 Turn the stitch length dial to "S".
 Set stitch width control between "3" - "5".
 (model Rome 3)
 Set stitch width control between "3" - "7".
 (model Rome 5/7)
 The stitch width can be adjusted to suit the fabric.

Stretch overlock: "T"

For fine knits, jerseys, neck edges, ribbing. (1)

Double overlock stitch: "X"

For fine knits, handknits, seams. (2)

All overlock stitches are suitable for sewing and neatening edges and visible seams in one operation.
 When neatening, the needle should just go over the edge of the fabric.

Attention:

Use new needles or ball point needles or stretch needle!

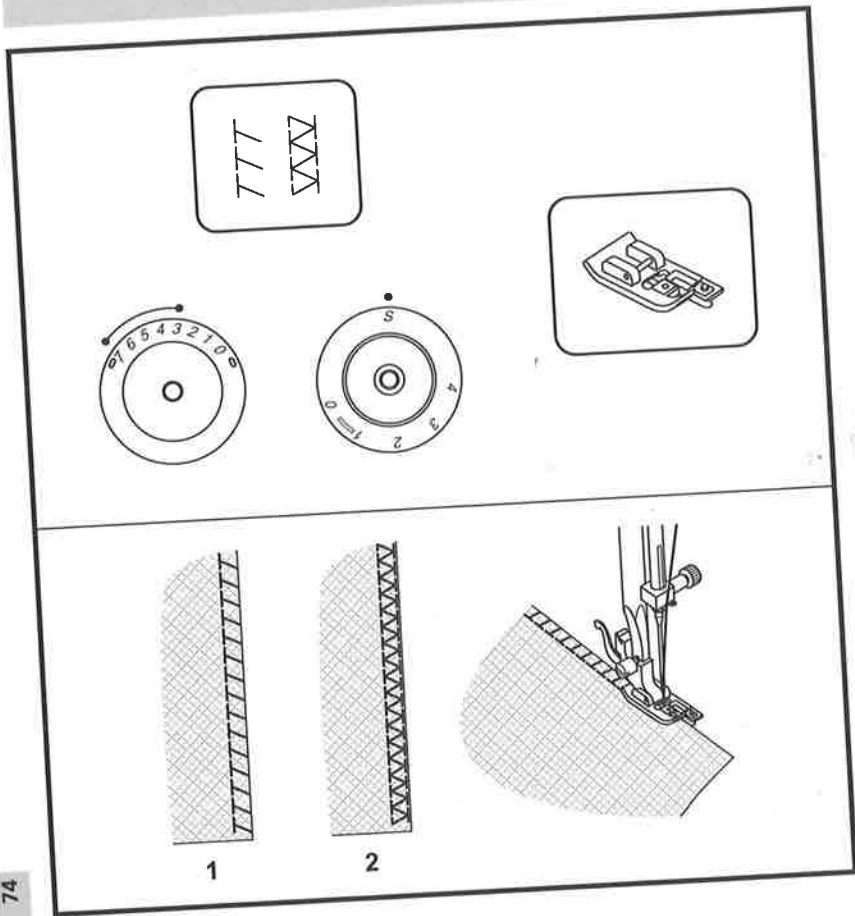

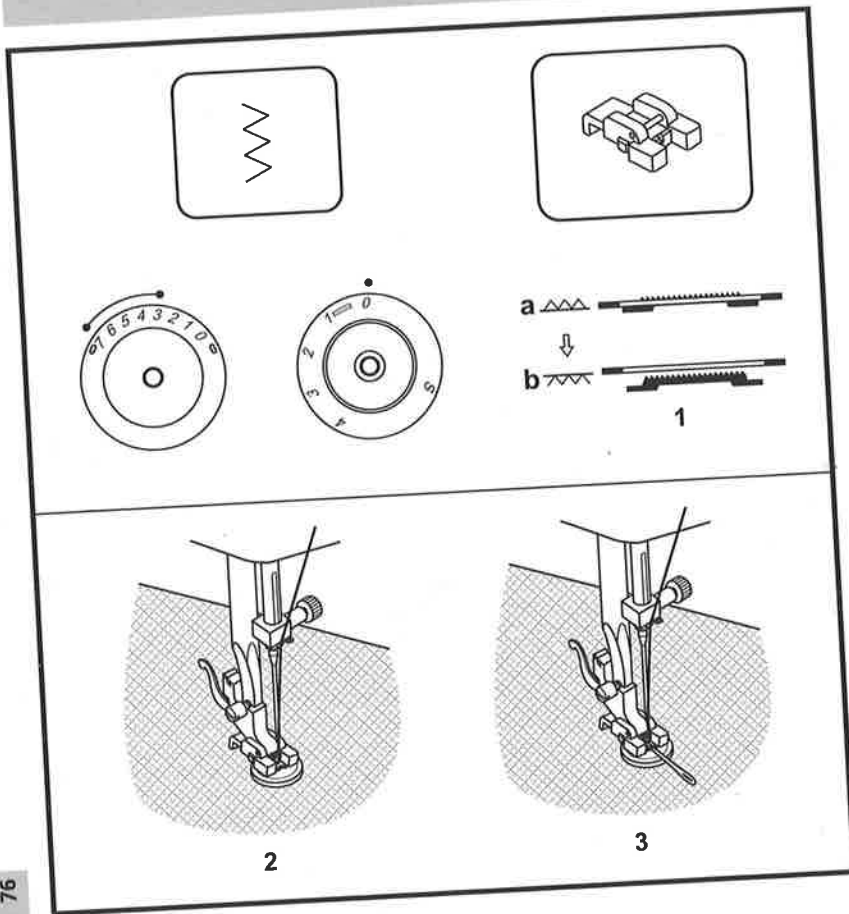

Move the drop feed control to right side to lower the feed dogs. (1)

Change presser foot to button sewing foot. Turn the stitch length dial to "0". Position the work under the foot. Place the button in the desired position, lower the foot. Set the pattern selector knob on zig zag stitch. Adjust the stitch width between "3" - "5" (model Rome 3), "3" - "7" (model Rome 5/7) according to the distance between the two holes of the button. Turn the handwheel to check that the needle goes cleanly into the left and right holes of the button. Set the pattern selector knob on straight stitch, and sew a few securing stitches. Set the pattern selector knob on zig zag stitch, and slowly sew on the button with about 10 stitches. Set the pattern selector knob on straight stitch, and sew a few securing stitches.

If a shank is required, place a darning needle on top of the button and sew. (3) For buttons with 4 holes, sew through the front two holes first (2), push work forward and then sew through the back two holes (3).

Move the drop feed control to left side for normal use.

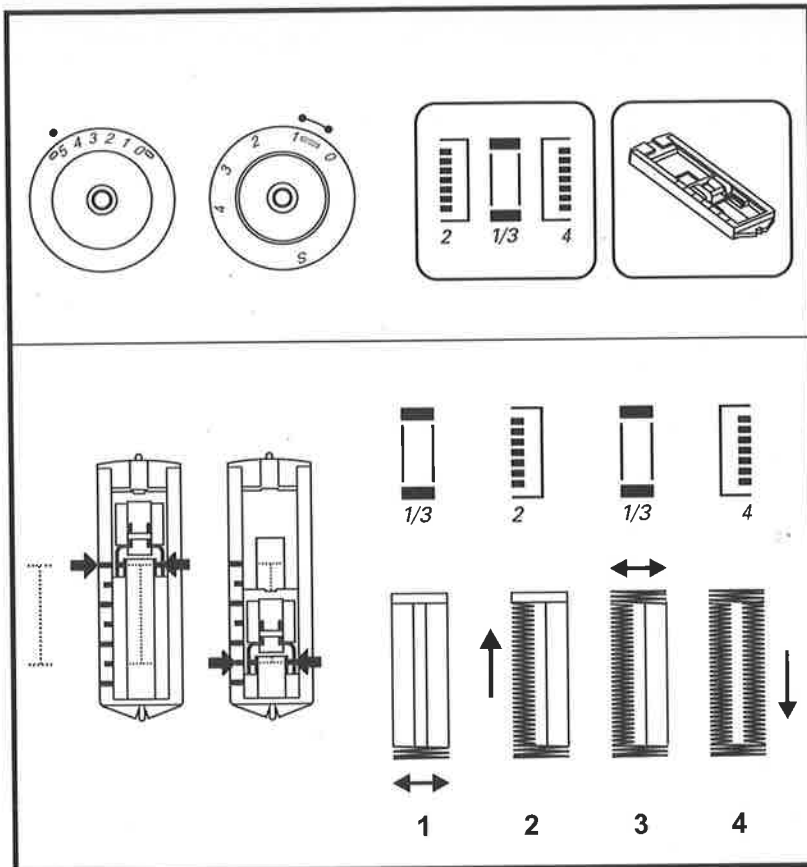
**Prepare**

Set the pattern selector dial to "□□□□".

1. Take off the all purpose foot and attach the buttonhole foot.
2. Measure diameter and thickness of button add together plus 0.3 cm (1/8") for bar tacks; mark buttonhole size on fabric.
3. Place fabric under the foot, so that mark on the buttonhole foot lines up with the marking on the fabric. Lower the foot, so that the center line of the fabric buttonhole comes to the center of the foot hole.

Adjust the stitch length dial between "0.5-1" for stitch density.

Note:

Density varies according to the fabric. Always test sew a buttonhole.

Follow the 4-step sequence changing from one step to another with the stitch pattern selector dial. Take care not to sew too many stitches in stages 1 and 3. Use seam ripper and cut buttonhole open from both ends towards the middle.

Tips:

- Slightly reduce upper thread tension to produce better results.
- Use a backing for fine or stretchy fabrics.
- It is advisable to use heavy thread or cord for stretch or knit fabrics.
- The zig-zag should sew over the heavy thread or cord.(simb)

Buttonhole-making is a simple process that provides reliable results.

Making a Buttonhole

1. Using tailor's chalk, mark the position of the buttonhole on the fabric.
2. Attach the buttonhole foot and set the pattern selection dial to "1".
3. Lower the presser foot aligning the marks on foot with the marks on the fabric as shown in fig. (A). (The front bar tack will be sewn first.)
4. Open the button plate and insert the button. (fig. B)
5. Lower the buttonhole lever and push it back (fig. C).
6. While gently holding the upper thread, start the machine.
7. Buttonhole stitching is done in the order shown in fig. (D).
8. Stop the machine when the buttonhole is sewn.

Making a Buttonhole on Stretch Fabrics (fig. E)

When sewing buttonholes on stretch fabric, place a gimp thread under the buttonhole foot.

1. Mark the position of the buttonhole on the fabric with the tailor's chalk, attach the buttonhole foot, and set the pattern selection dial to "1".
2. Hook the gimp thread onto the back end of the buttonhole foot, then bring the two gimp thread ends to the front of the foot, insert them into the grooves and temporarily tie them there.
3. Lower the presser foot and start sewing.
*Set the stitch width to match the diameter of the gimp thread.
4. Once sewing is completed, gently pull the gimp thread to remove any slack, then trim off the excess.

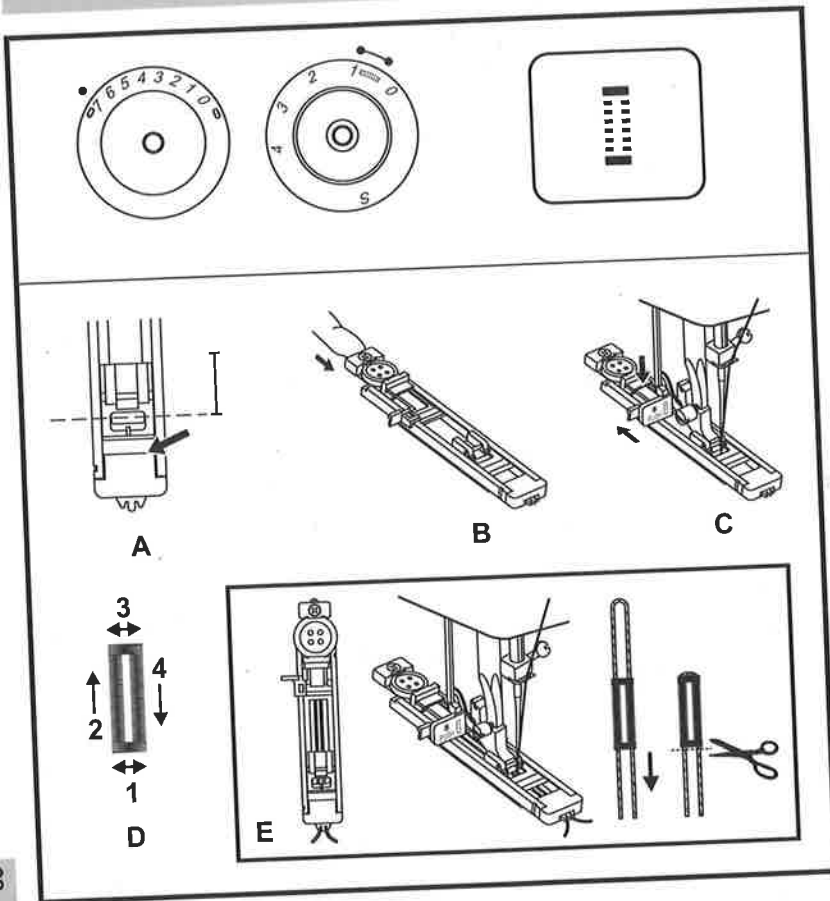

Set the machine as illustrated. Pattern selector on "1".

Set stitch length control between "2.5"-
"4" (according to thickness of fabric).
Turn the stitch width dial to "0".

The zip foot can be inserted right or left,
depending on which side of the foot you
are going to sew. (1)

To sew past the zip pull, lower the needle
into the fabric, raise the presser foot and
push the zip pull behind the presser foot.
Lower the foot and continue to sew.

It is also possible to sew in a length of
cord, into a bias strip to form a 'welt'. (2)

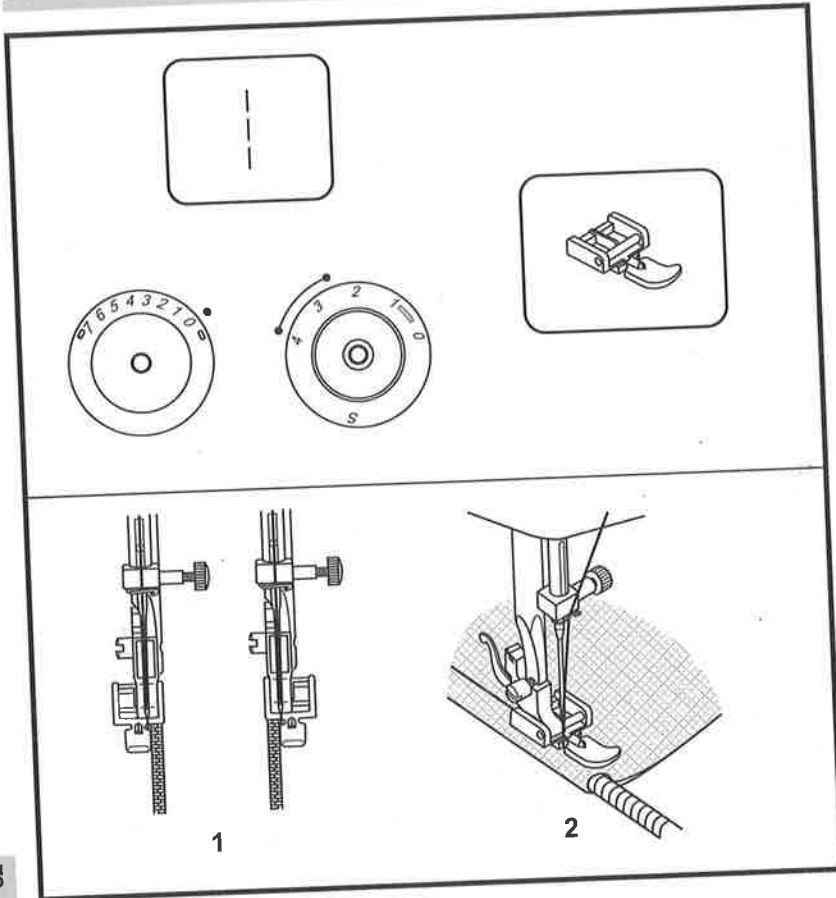

Presser foot available as optional accessory

For hems in fine or sheer fabrics.

Set the machine as illustrated.
 Pattern selector on "1".
 Set stitch length control between
 "2.5" - "4".
 Turn the stitch width dial to "0".

Neaten the edge of the fabric. At the beginning of the hem, turn under the edge twice by about 3 mm (1/8") and sew 4-5 stitches to secure. Pull the thread slightly towards the back. Insert the needle into the fabric, raise the presser foot and guide the fold into the scroll on the foot. (1)

Gently pull the fabric edge towards you and lower the presser foot. Begin sewing, guiding the fabric into the scroll by holding it upright and slightly to the left. (2)

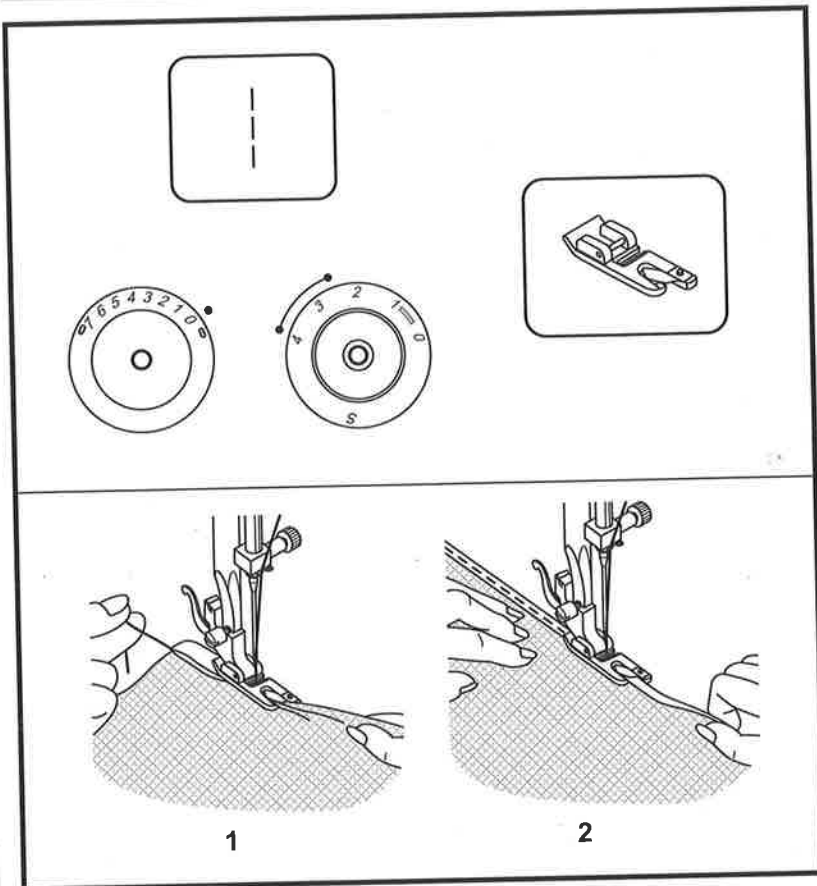

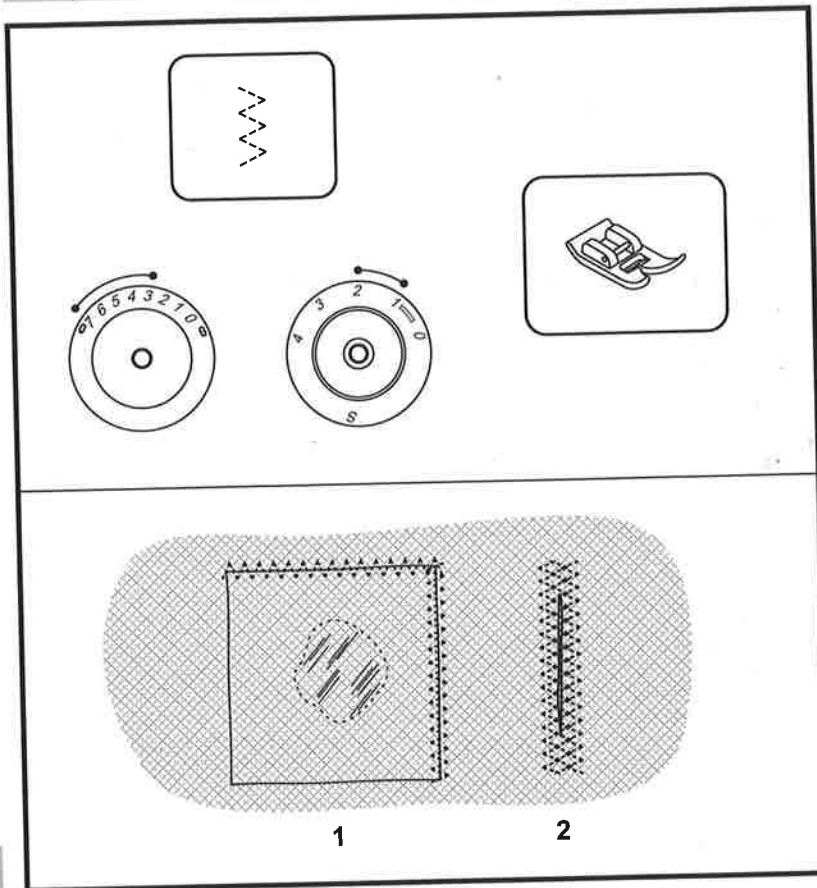

Sewing on lace and elastic, darning, mending, reinforcing edges.

Set the machine as illustrated. Pattern selector on "3".

Set stitch length control between "1" - "2".

Set stitch width control between "3" - "5", (model Rome 3)

Set stitch width control between "3" - "7", (model Rome 5/7)

Place patch in position. The stitch length can be shortened to produce very close stitches. (1)

When mending tears, it is advisable to use a piece of backing fabric to reinforce. The stitch density can be varied by adjusting the stitch length. First sew over the center and then overlap on both sides. Depending on the type of fabric and damage, sew between 3 and 5 rows. (2)

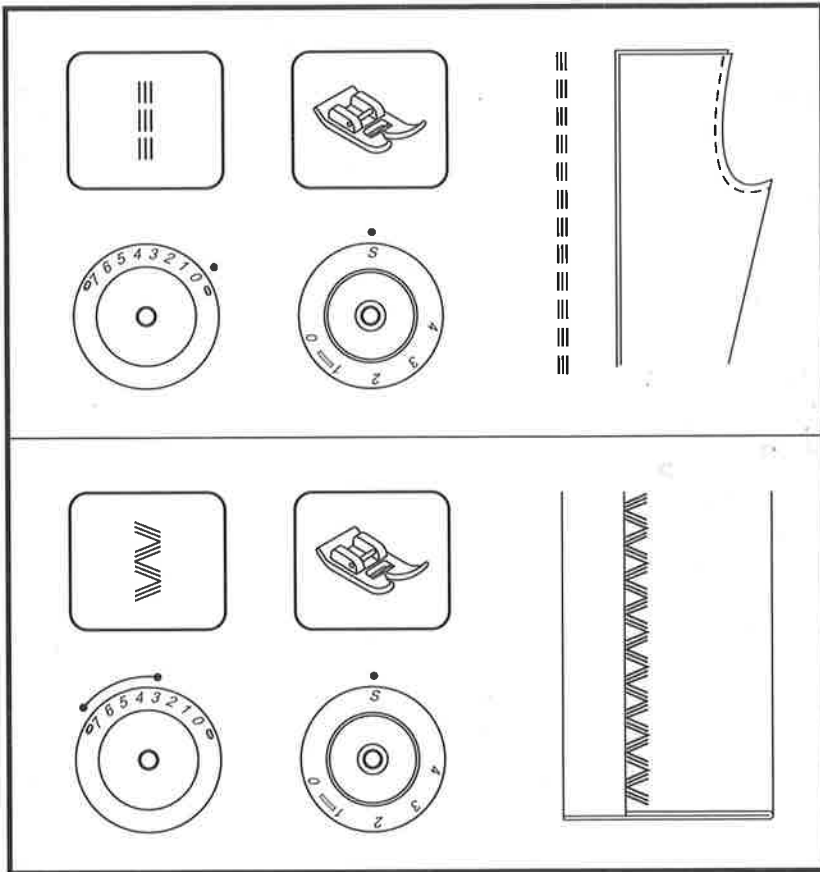

Triple straight stitch: (1)

Pattern selector on "1".
 For hardwearing seams.
 Turn the stitch length dial to "S".
 Turn the stitch width dial to "0".
 The machine sews two stitches forwards
 and one stitch backwards.
 This gives triple reinforcement.

Triple zig-zag: (2)

Pattern selector on "2".
 For hardwearing seams, hems and
 decorative seams.
 Turn the stitch length dial to "S" and
 adjust the stitch width dial between "3"
 and "5". (model Rome 3)

Turn the stitch length dial to "S" and
 adjust the stitch width dial between "3"
 and "7". (model Rome 5/7)

Triple zig-zag is suitable for firm fabrics like
 denim, corduroy, etc.

Seams, hems, T-shirts, underwear, etc.

Set the machine as illustrated.

Pattern selector on "8".

Turn the stitch length dial to "S".
Set stitch width control between "4" - "5".
(model Rome 3)

Set stitch width control between "4" - "7".
(model Rome 5/7)

This stitch can be used for all types of
jersey as well as for woven fabrics. (1)

Sew at 1 cm (1/4") from the fabric edge
and trim the surplus fabric. (2)

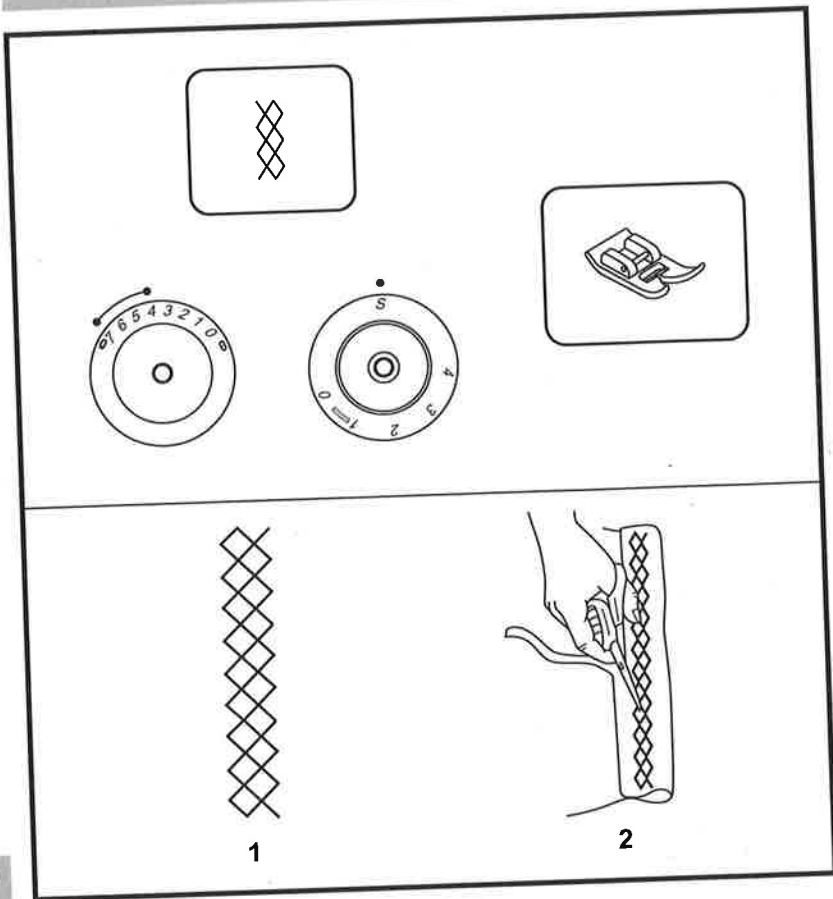

Presser foot available as optional accessory

Decorative effects, cushions, tablecloths, etc.

Set the machine as illustrated. Various stitches are suitable for sewing on cord, e.g. Zig-zag, Triple zig-zag, decorative stitches.

Pattern selector on "Z"

Set stitch length control between "1" - "4"

Set stitch width control between "3" - "5". (model Rome 3)

Set stitch width control between "3" - "7". (model Rome 5/7)

Insert the cord between the spring covering the cord groove and the foot. The cord should run in the groove. One, two or three cords can be sewn on. The stitch width is adjusted according to the number of cords and the stitch selected. (1/2)

- a. model Rome 3
- b. model Rome 5/7

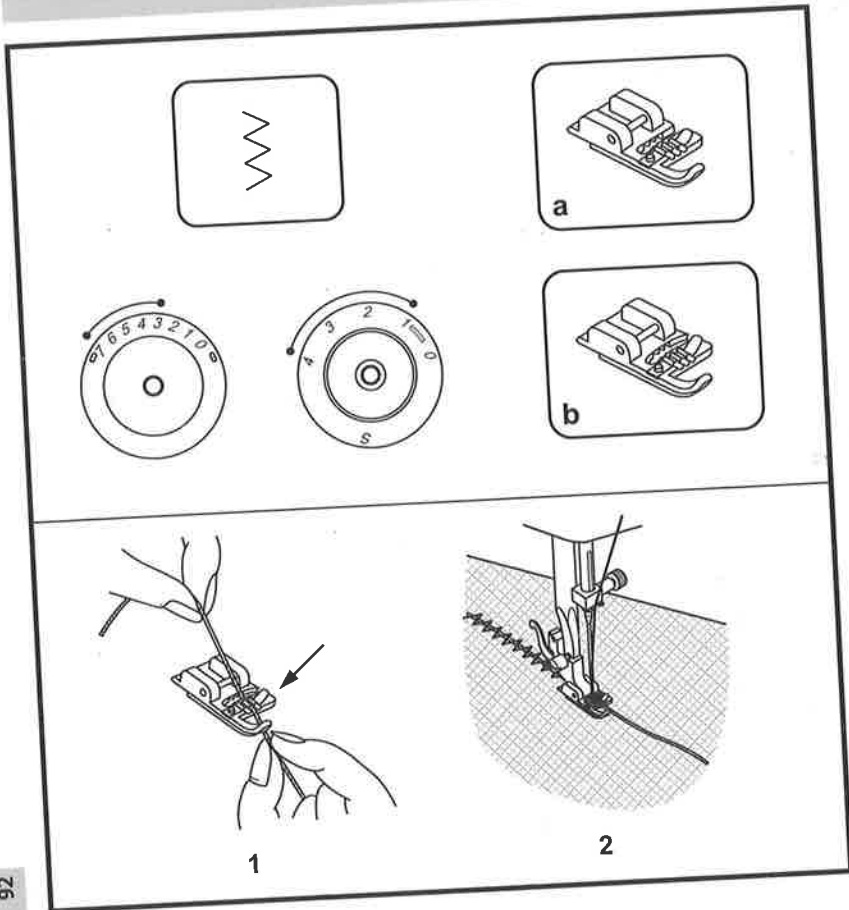

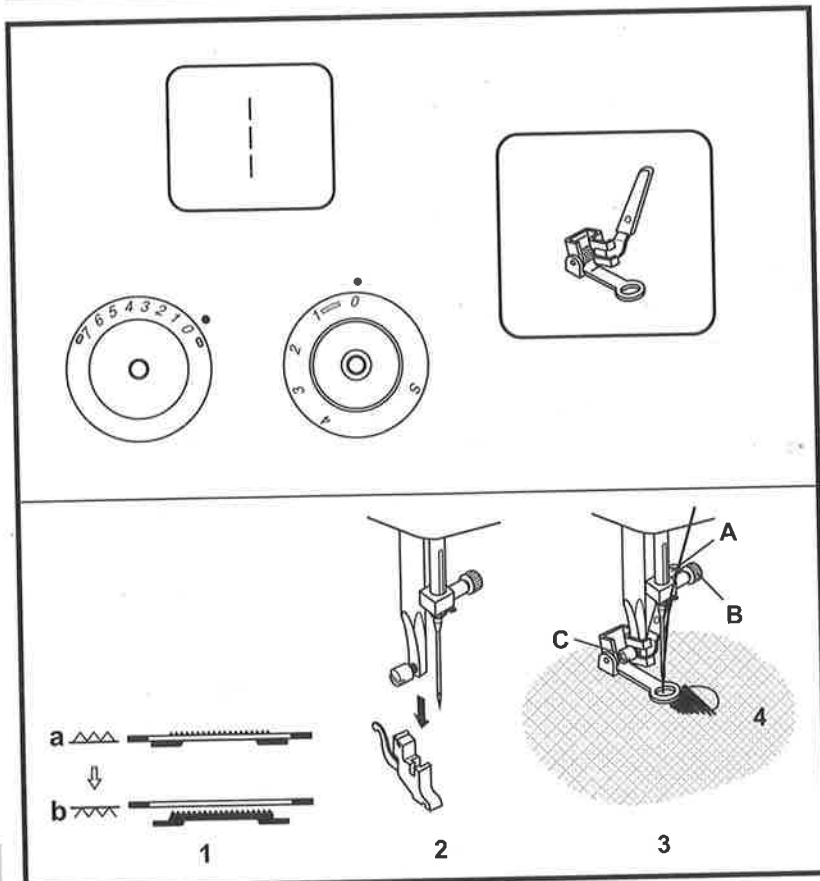

Presser foot available as optional accessory

Set the machine as illustrated. Move the drop feed control to right side to lower the feed dogs. (1)

Remove the presser foot holder. (2) (see page 32)

Pattern selector on " | ".

Turn the stitch length dial to "0".
Turn the stitch width dial to "0".

Attach the darning foot to the presser foot bar. The lever (A) should be behind the needle clamp screw (B). Press the darning foot firmly from behind with your index finger and tighten the screw (C). (3)

First sew round the edge of the hole (to secure the threads). (4) First row: Always work from left to right. Turn work by 1/4 and oversew.

A darning ring is recommended for easier sewing and better results.

Move the drop feed control to left side for normal use.

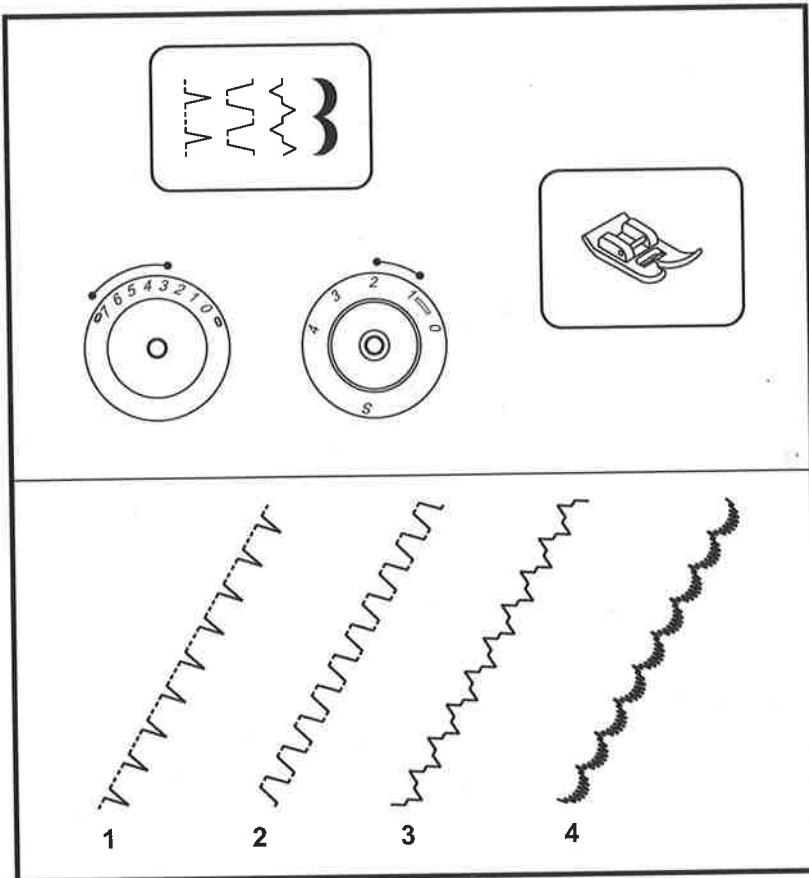

Set the machine as illustrated.
Turn the stitch width dial and stitch length dial to suit the fabric.

Set stitch length control between "1" - "2".

Set stitch width control between "3" - "5". (model Rome 3)

Set stitch width control between "3" - "7". (model Rome 5/7)

Shell hem (1)

Pattern selector on "B"

For decorative edges.

Suitable for edges on sheer, fine and stretch fabrics. The larger stitch should go just over the edge of the fabric to create the shell effect.

Rampart (2)

Pattern selector on "Z"

For flat joining seams, sewing on elastic, visible hems.

This stitch can be used for firm, thicker fabrics.

Bridging (3)

Pattern selector on "X"

For seams, place mats, tablecloths.

Decorative joining seam for a fagotted effect. Gathering with cord or shirring elastic.

Scallop stitch (4)

Pattern selector on "J"

For a delicate edge finish along the edge of fabric.

Set the machine as illustrated.
Turn the stitch width dial and stitch length dial to suit the fabric.

Stitch length control "0.5 - 1"
Set stitch width control "3" - "5" (model Rome 3)
Set stitch width control "3" - "7" (model Rome 5/7)

For edges, tablecloths, bed linen, cuffs, embroidery. For an attractive, decorative effect, adjust the stitch width to maximum. Embroidery thread adds to effect.

Square stitch (1)
Pattern selector on "Σ"
(model Rome 3/5/7)

Decor stitch (2)
Pattern selector on "Σ"
(model Rome 5/7)

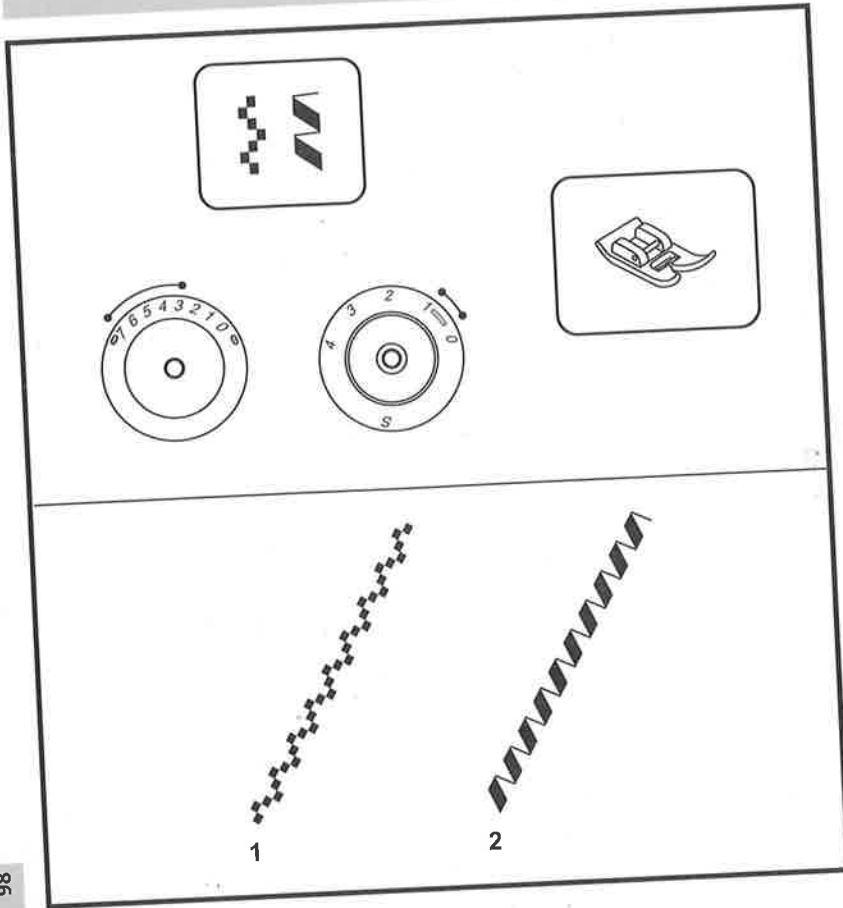

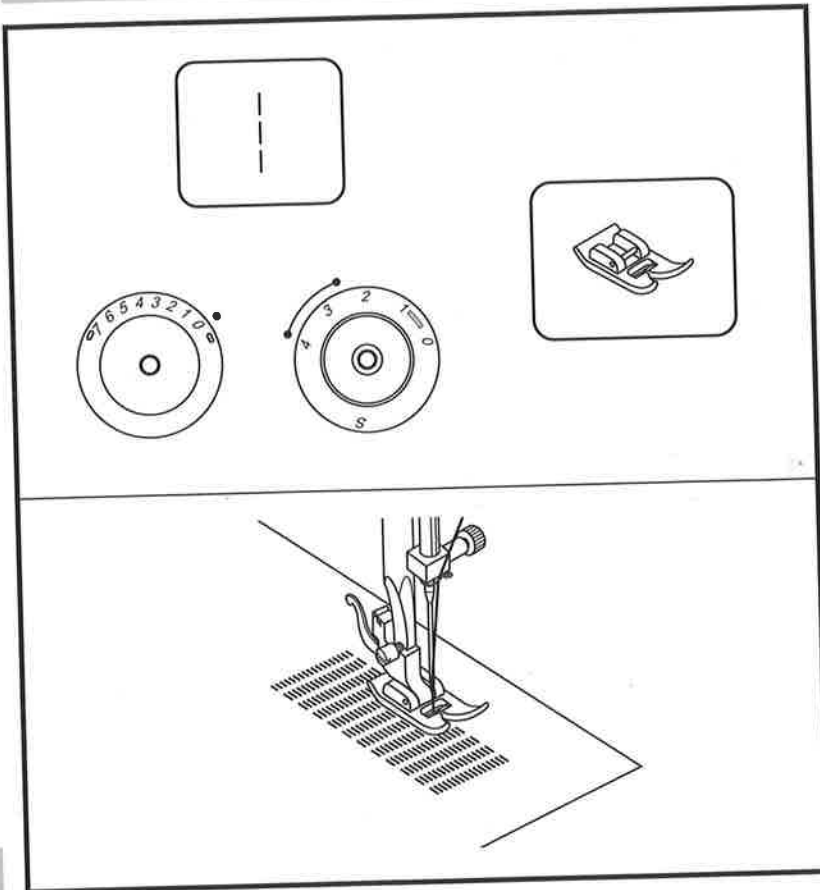

- Turn stitch length dial to the desired length.
- Pattern selector on "1".
- Center needle position.
- Position the fabric to be darned under the presser foot together with the under laying fabric to be used.
- Lower the presser foot and alternately sew forward or reverse using the reverse sewing lever.
- Repeat this motion until the area to be darned is filled with rows of stitching.

For reverse sewing instructions, see figure "A", page 50.

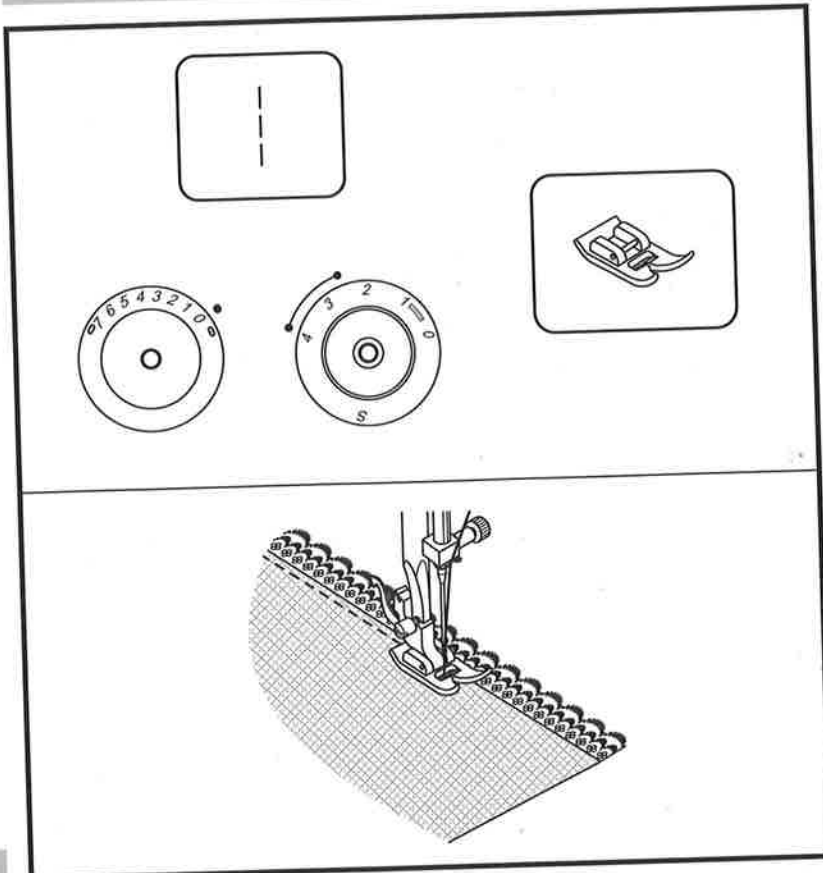

- Turn stitch length dial to the desired length.
- Pattern selector on "1".
- Center needle position.
- Fold in the edge of the fabric (approximately 6 mm 1/4").
- Place the lace under the folded edge of the fabric allowing it to underlap the fabric slightly as required by the pattern of the lace.
- Sew on the edge of the fabric fold.
- You can add a decorative touch by using the satin stitch to sew on the lace.

- Turn stitch length dial to the desired length.
- Pattern selector dial on "Z".
- Turn zig-zag width dial to small width.
- Cut out the applique design and baste it to the fabric.
- Sew slowly around the edge of the design.
- Trim excess material outside the stitching. Make sure not to cut any stitches.
- Remove the basting thread.
- Tie top and bottom thread under the applique to avoid unraveling.

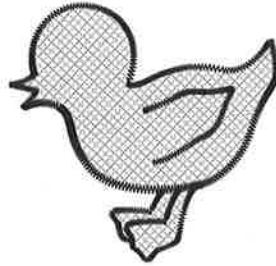
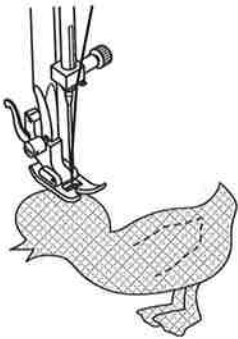
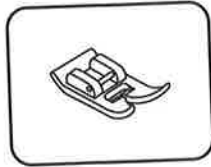
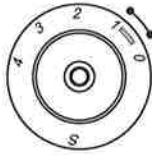
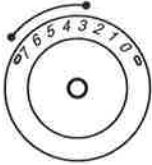
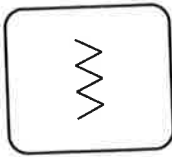

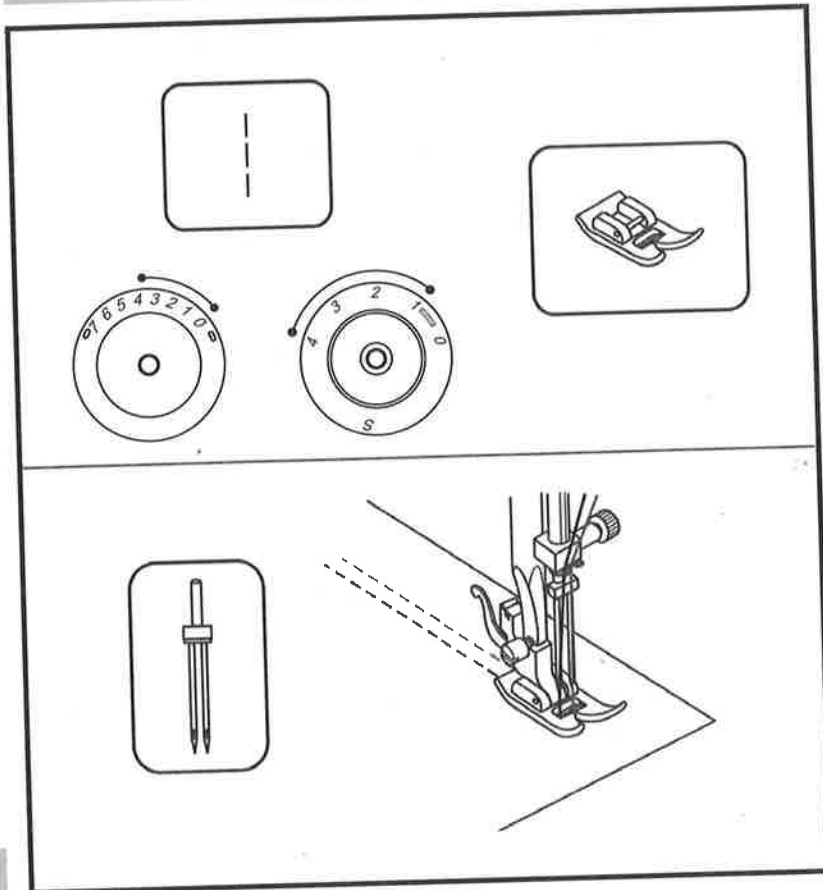

- Turn stitch length dial to the desired stitch length.
- Pattern selector on "1"
- Center needle position.
- Make sure that the two threads used to thread the twin needle are of the same weight. You can use one or two colors.
- Insert the twin needle in the same way as single needle. Flat side of needle should face away from you.
- Follow instructions for single needle threading. Thread each needle separately.

Please note:

When sewing with twin needle, always proceed slowly, and make sure to maintain low speed to insure quality stitching. When using twin needle on zig-zag make sure the stitch width dial is set between "0" and "2.5". Do not use twin needle at setting above "2.5". (model Rome 3) When using twin needle on zig-zag make sure the stitch width dial is set between "0" and "4". Do not use twin needle at setting above "4". (model Rome 5/7)

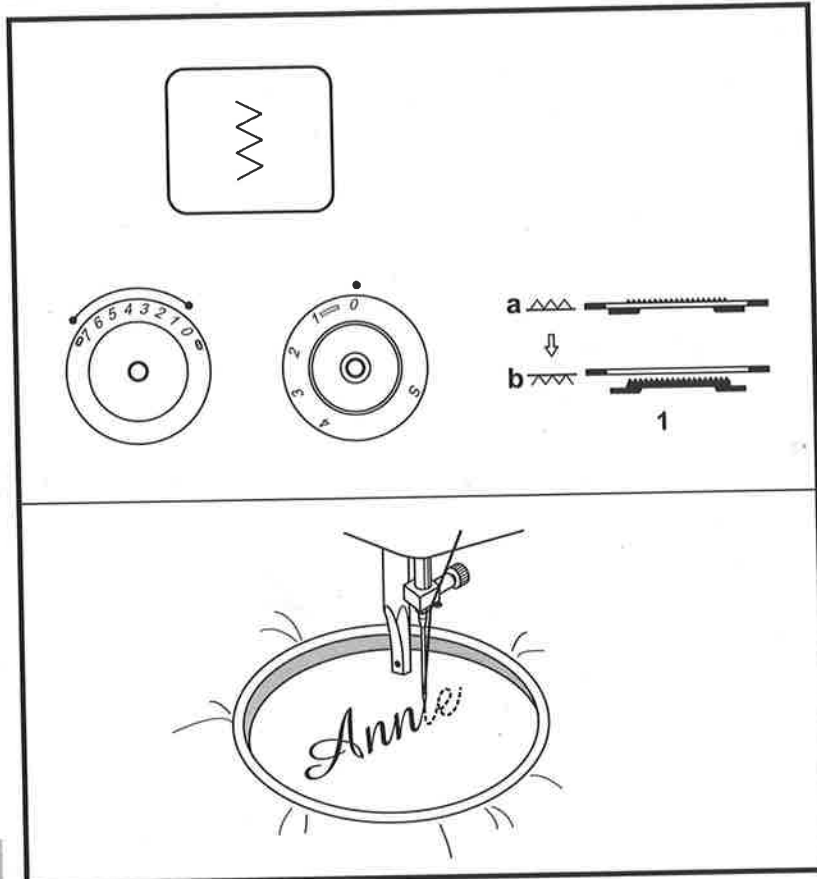

Embroidery hoop available as optional accessory

- Set the machine as illustrated.
- Pattern selector on "Z"
- Remove the presser foot and the presser foot holder.
- Move the drop feed control to right side to lower the feed dogs. (1)
- Lower presser foot lever before starting to sew.
- Turn the stitch length dial to "0".
- Adjust the stitch width according to the size of lettering or design.

Preparation for Monogramming and Embroidering

- Draw the desired lettering or design on the right side of the fabric.
- Stretch the fabric between embroidery hoop as firmly as possible.
- Place the fabric under the needle. Make sure the presser foot bar is down in its lowest position.
- Turn the balance wheel towards you to bring up the lower thread through the fabric. Sew a few securing stitches at the starting point.
- Hold the hoop with both hands and guide it.

Move drop feed control to the left side for normal use.

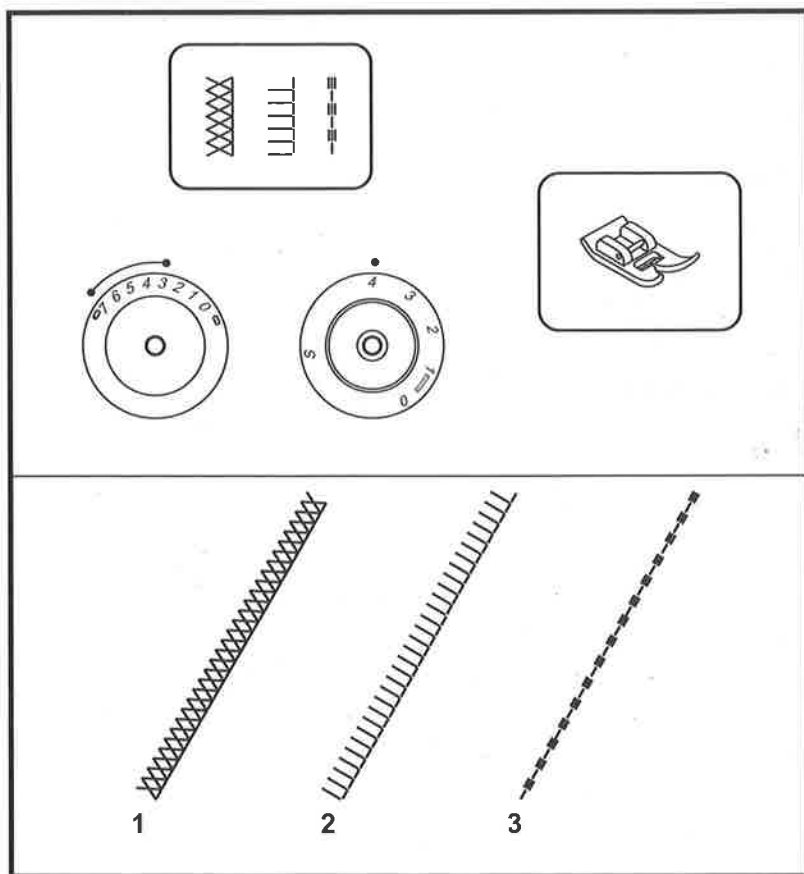

Set the machine as illustrated.
 Turn the stitch width dial and stitch length dial to suit the fabric.
 Set stitch length control "4"
 Set stitch width control "3" - "5"
 (model Rome 3)
 Set stitch width control "3" - "7"
 (model Rome 5/7)

Quilt (1)

Pattern selector on "zigzag"
 For all fabrics and all types of work.

Quilt (2)

Pattern selector on "horizontal lines"
 For all fabrics and all types of work.

Hand look quilt stitch (3)

Pattern selector on "vertical lines"
 For all fabrics and all types of work which should have a hand-sewn look.
 (model Rome 5/7)
 The bobbin thread must come through the right side. Depending on the fabric used increase the upper tension.
 Use monofilament thread 0 hand stitch effect.
 Balance, adjust if necessary

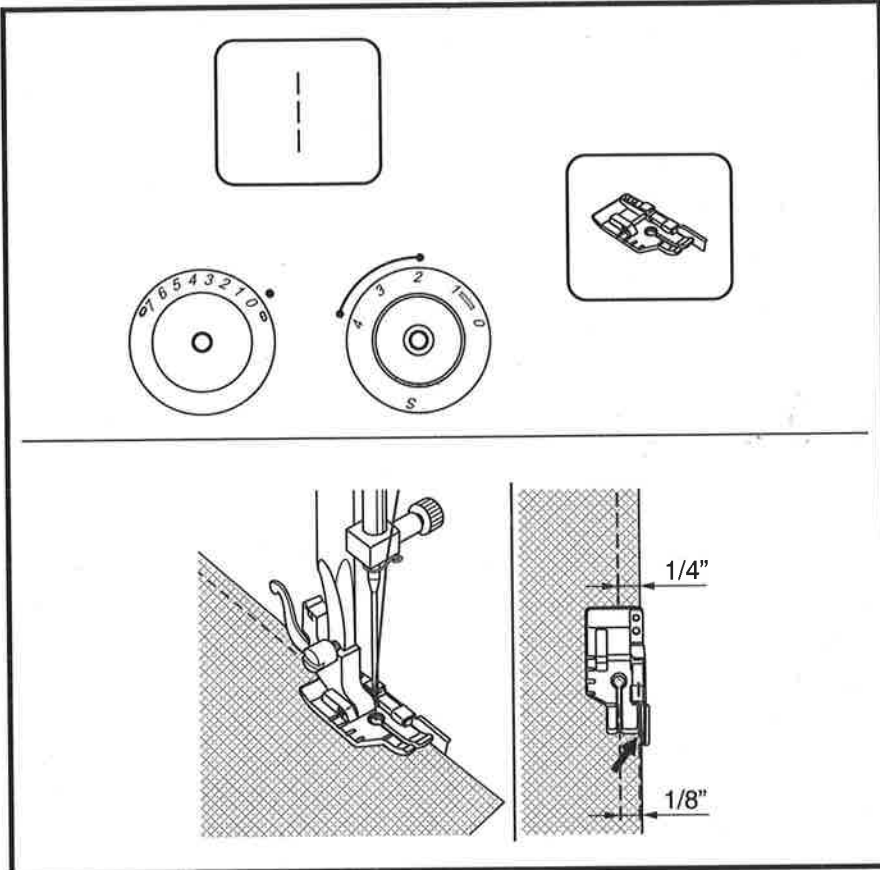

1/4" Quilting foot available as optional accessory

Set stitch length control between "2" - "4".

Pattern selector on "1".
Center needle position.

Procedure:

Seam allowance 1/4 inch (6 mm)
Place the fabric under the presser foot so that the raw edges are aligned with the seam guide sew seam by guiding the fabric along the guide so that perfect 1/4 inch seams are stitched.

Seam allowance 1/8 inch (3 mm)
Position the fabric under the foot raw edges aligned with the outer edge of the right toe (see arrow). Stitch perfect 1/8 inch seams.

The notches on the left edge of the foot are 1/4 inch in front and behind the needle located. The centre notch is in line with the point of needle penetration. The markings are helpful when the patchwork seam should start or end 1/4 inch in from the fabric edge.

Caution:

This foot can only be used with straight stitch in centre position.

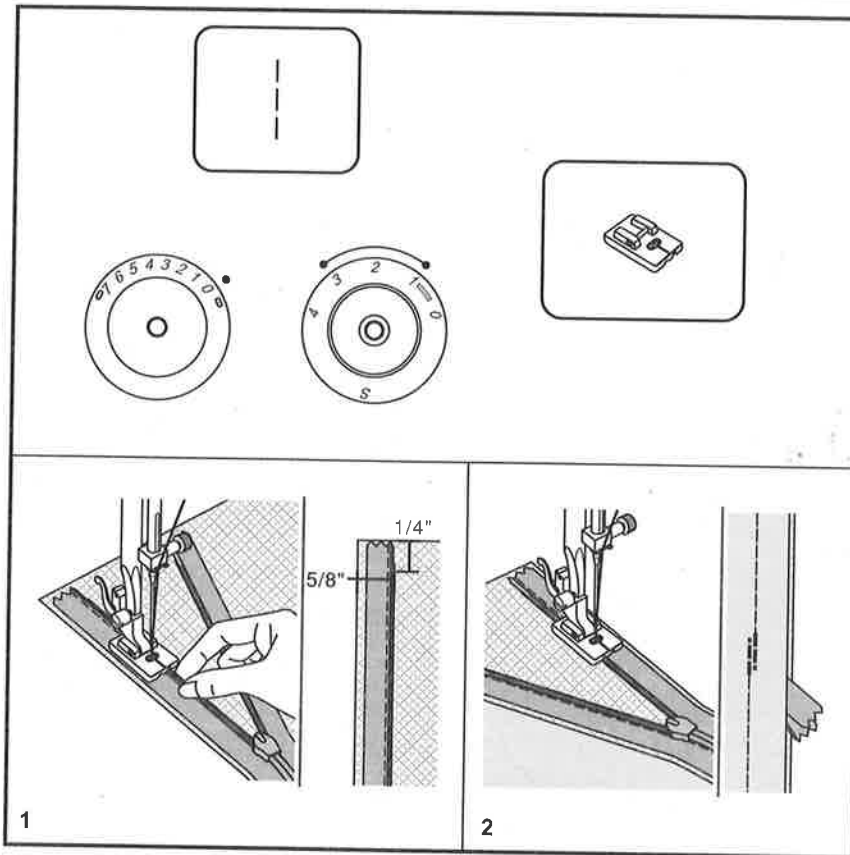

This foot is available as special accessory.

This **foot** is used to insert invisible zippers so that they are covered by the seam, and thus **hidden**. Attach the invisible zipper foot to the machine. Adjust needle center position and straight **stitch**. Stitch length depends from the **fabric**. Adjust 1,0 - 3,0 mm. Place open zipper face - down on right side of fabric as shown in **picture 1**. Place the fabric edge at the 5/8 inch marking line on the needle plate surface. Place the zipper 1/4 inch below raw edge of garment.

With **right-hand** groove of foot over coil, stitch zipper until the foot hits the slider. Remove the garment from the machine.

To attach the other half of the zipper, place the **fabric edge** on the 5/8 inch marking line on the needle plate as shown in **picture 2**. With the left-hand groove of foot over coil, stitch zipper until the foot hits the slider.

Close zipper. **Fold** the fabric that the zipper is on **ride - hand** side out of the way as shown in **picture 2**.

Use a pin for fixing the fabric. Change to regular sewing foot and sew as close as possible with straight stitch against the zipper.

At last carry out tie off with some forward and reverse stitches.

Presser foot available as optional accessory

1. Attach the gathering foot.
Pattern selector on "1"
2. Set stitch length control between "2.5" - "4"
3. Sew a single row or multiple rows of straight stitches.
4. If more gathering is required, loosen the upper thread (to about 2) so that the lower thread lies on the under side of the material.
5. Pull the lower thread to gather more of the material.

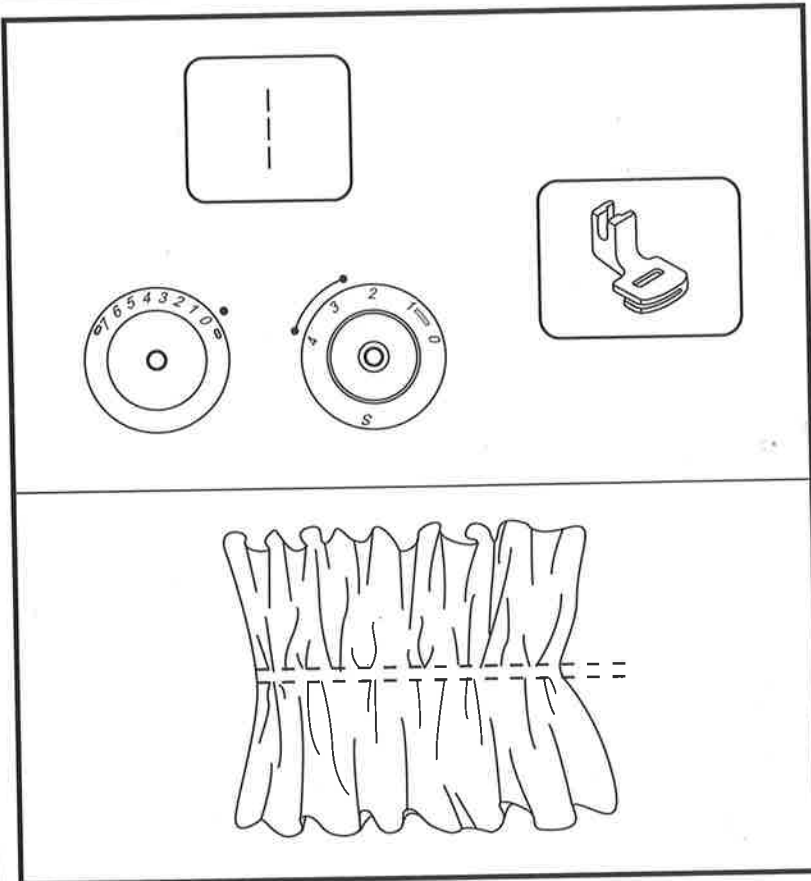

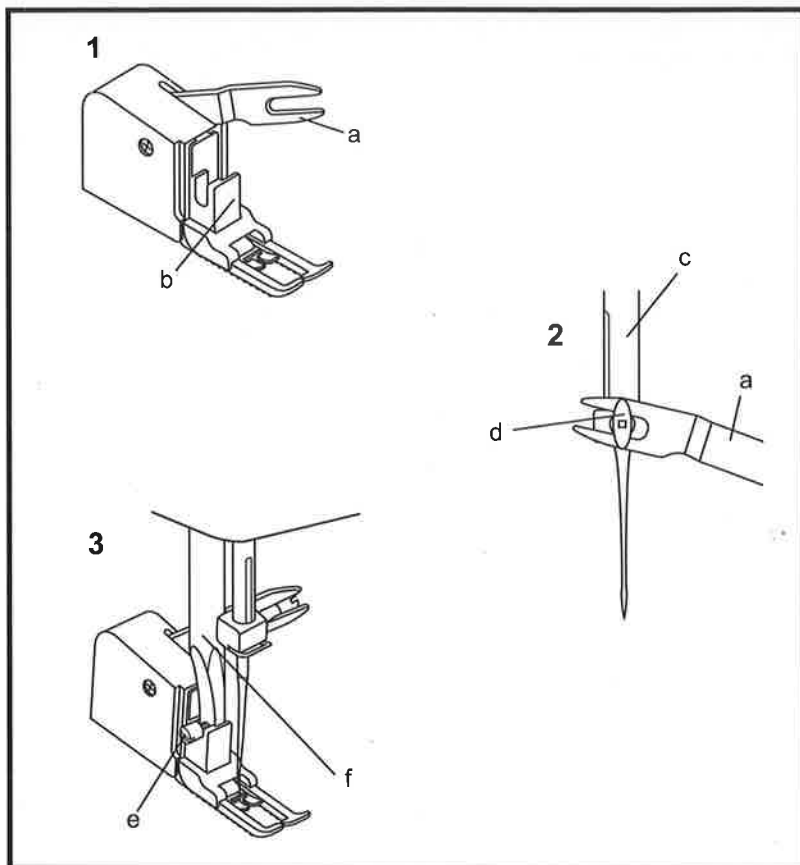

Presser foot available as optional accessory

Always try to sew first without the walking foot accessory which should be used only when necessary.

The "Walking foot" accessory equalizes the feeding of the upper and lower layers of fabric and improves the matching of plaids, stripes and patterns. This foot helps to prevent uneven feeding of very difficult fabrics.

1. Lift the presser foot bar.
2. Remove the "presser foot holder" (see page 32)
3. Attach the "walking foot" to the machine in the following way.
 - i) The fork arm should fit into the needle screw and clamp. (2)
 - ii) Slide the plastic "attaching head" from your left to right so that it is fitted on the "presser foot bar".
 - iii) Lower the "presser foot bar".
 - iv) Tighten the fixation screw
4. Make sure both the "needle screw" and the "fixation screw" are tight.
5. Draw the bobbin thread up. Lay both threads to the back under the foot

- a Fork arm
- b Attaching head
- c Needle bar
- d Needle screw & clamp
- e Presser bar attaching screw
- f Presser foot bar

Presser foot available as optional accessories

Always try to sew first without the walking foot accessory which should be used only when necessary.

The "Walking foot" accessory equalizes the feeding of the upper and lower layers of fabric and improves the matching of plaids, stripes and patterns. This foot helps to prevent uneven feeding of very difficult fabrics.

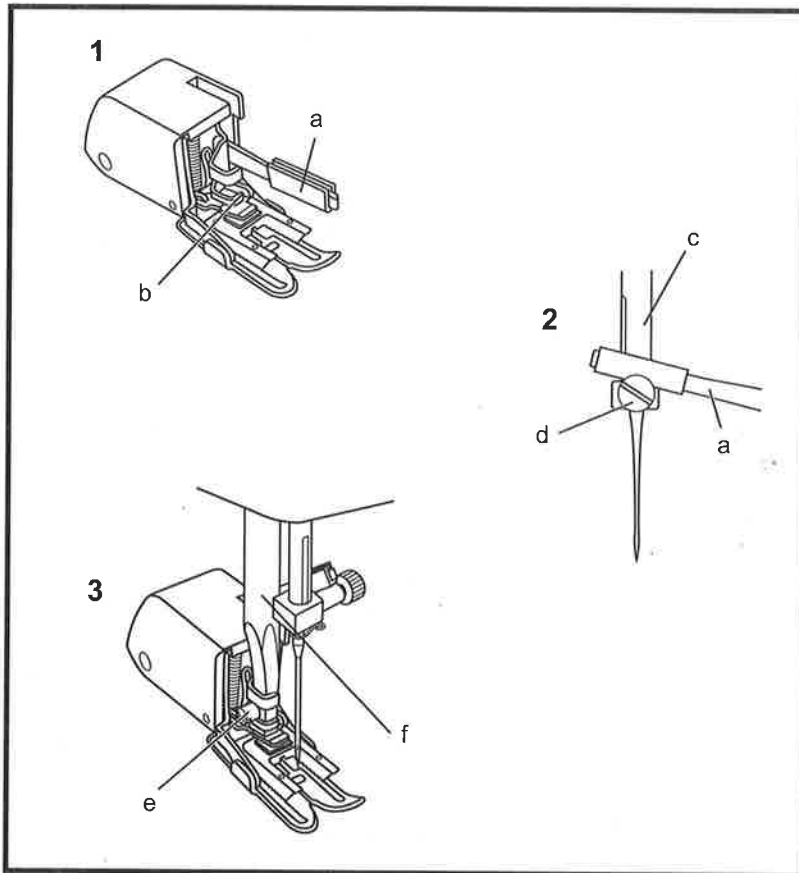

1. Lift the presser foot bar.
2. Remove the "presser foot holder" (see page 32)
3. Attach the "walking foot" to the machine in the following way.
 - i) The arm should fit over the needle screw and clamp. (2)
 - ii) Slide the plastic "attaching head" from your left to right so that it is fitted into the "presser foot bar".
 - iii) Lower the "presser foot bar".
 - iv) Tighten the fixation screw.
4. Make sure both the "needle screw" and the "fixation screw" are tight
5. Draw the bobbin thread up. Lay both threads to the back under the foot

- a Fork arm
- b Attaching head
- c Needle bar
- d Needle screw & clamp
- e Presser bar attaching screw
- f Presser foot bar

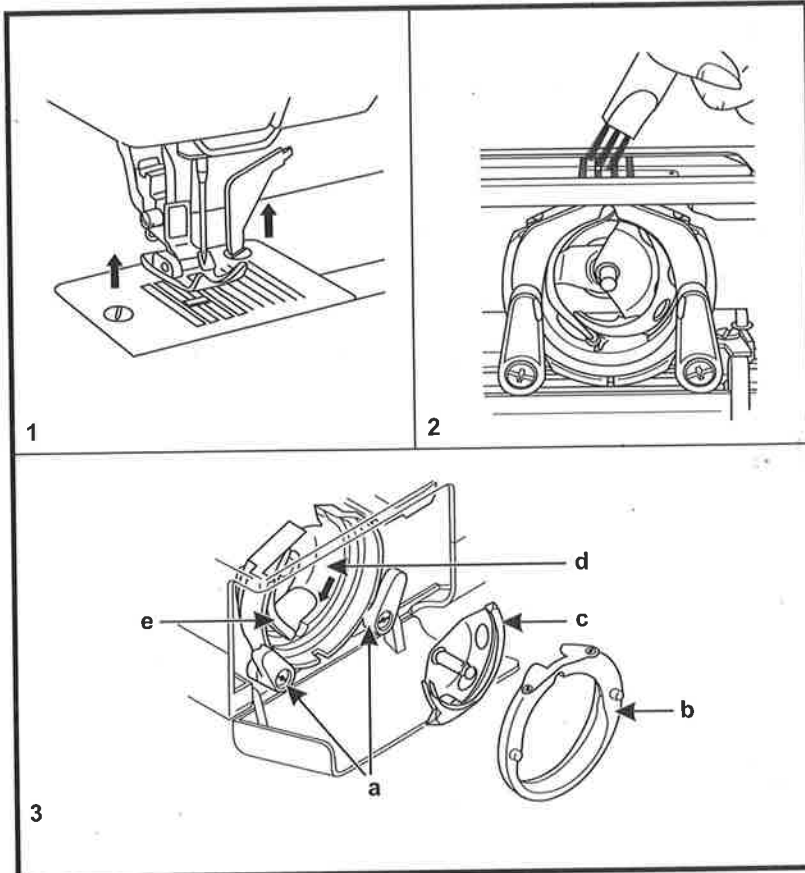
**Caution:**

Main switch on "0". Disconnect machine from electricity supply before inserting or removing any parts and before cleaning.

Cleaning**Remove the stitch plate:**

Raise the needle to its highest position. Remove the extension table and open the hinged front cover on the front of the free arm. Loosen the two screws, then remove the stitch plate. (1)

Cleaning and lubricating the hook:

Take out the bobbin case by opening its latch and pulling it out from the shuttle race (3). Snap the two hook retaining arms (a) outwards. Remove the hook race cover (b) and the hook (c). Clean first the feed dogs with the brush (2). Then clean with a soft cloth hook (c), hook race (d) and hook race cover (b). Lubricate at the point (d) (1 to 2 drops) with sewing machine oil. Turn the handwheel until the driver (e) is in the left position. Replace the hook (c) then the hook race cover (b), snap back the two retaining arms (a). Insert bobbin and bobbin case and replace the stitch plate.

Note:

When the needle is lowered, the shuttle hook cannot be removed.

Important:

Fabric, fluff and threads must be removed regularly. Your machine should be serviced at regular intervals at your local dealer.

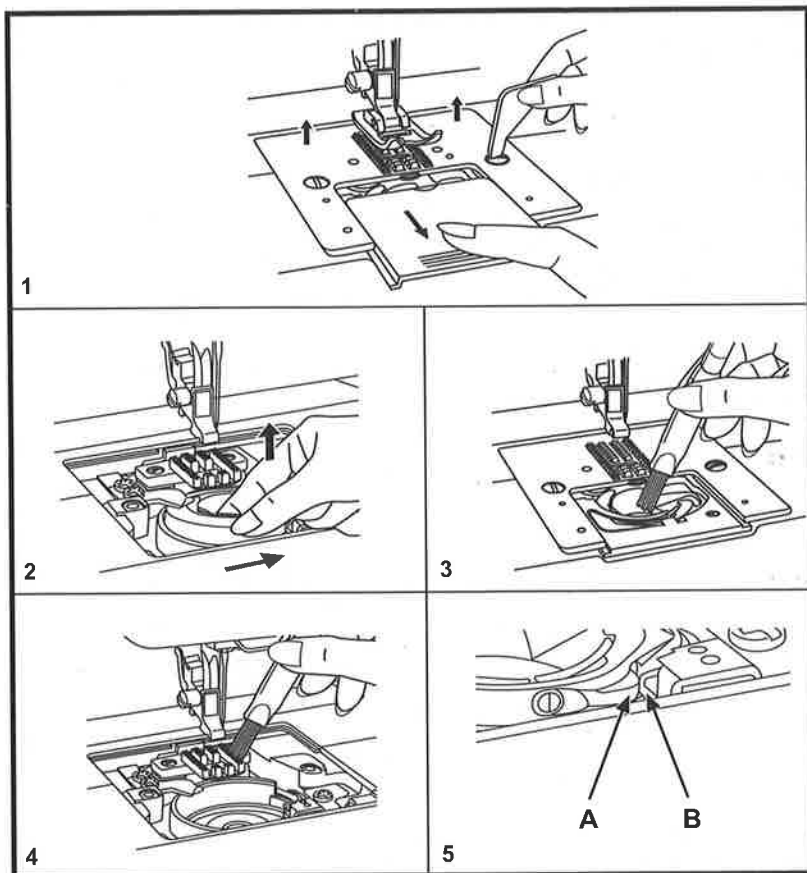
**Caution:**

Main switch on "0". Disconnect machine from electricity supply before inserting or removing any parts and before cleaning.

Cleaning**Remove the stitch plate**

1. Raise the needle to its highest position. Remove the presser foot. Open the bobbin cover plate, remove the two screws, then remove the stitch plate.
2. Press the bobbin holder toward the right, lift it up and remove it.
3. Clean the hook race.
4. Clean the feed dog and bobbin holder with a brush, then clean them with a soft, dry cloth.
5. Replace the bobbin holder into the hook race so that the tip (A) fits to the stopper (B). Replace the stitch plate and the two screws. Insert the bobbin. Close the bobbin cover plate, replace the presser foot.

Important:

Fabric, fluff and threads must be removed regularly. **The drop-in system MUST NOT be lubricated.** Your machine should be serviced at regular intervals at your local dealer.

Attention: Turn the power switch off and wait until the lamp has cooled down before touching it.

Loosen the screw (a) on the left side of the sewing head and remove the face plate (b).
(1)

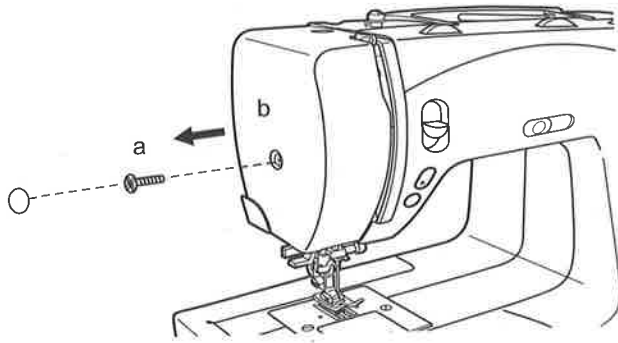

1

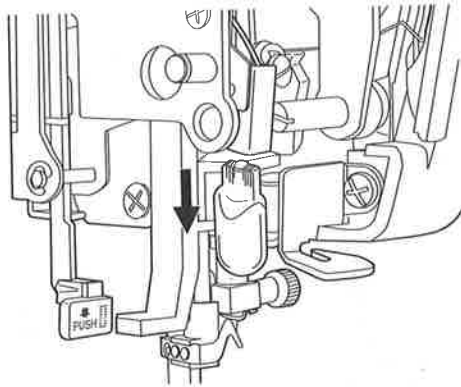

2

Pull light bulb downward to remove.
Replace the bulb with same type rated
5w/12V.
Set the face plate and tighten the screw.
(2)

Problem	Cause	Correction
Upper thread breaks	<ol style="list-style-type: none"> 1.The machine is not threaded correctly 2.The thread tension is too tight 3.The thread is too thick for the needle 4.The needle is not inserted correctly 5.The thread is round wound the spool holder pin 6.The needle is damaged 	<ol style="list-style-type: none"> 1.Rethread the machine 2.Reduce the thread tension (lower number) 3.Select a larger needle 4.Remove and reinsert the needle (flat side towards the back) 5.Remove the reel and wind thread onto reel 6.Replace the needle
Skipped stitches	<ol style="list-style-type: none"> 1.The needle is not inserted correctly 2.The needle is damaged 3.The wrong size needle has been used 4.The foot is not attached correctly 	<ol style="list-style-type: none"> 1.Remove and reinsert needle(flat side towards the back) 2.Insert a new needle 3.Choose a needle to suit the thread and fabric 4.Check and attach foot correctly
Needle breaks	<ol style="list-style-type: none"> 1.The needle is damaged 2.The needle is not correctly inserted 3.Wrong needle size for the fabric 4.The wrong foot is attached 	<ol style="list-style-type: none"> 1.Insert a new needle 2.Insert the needle correctly (flat side towards the back) 3.Choose a needle to suit the thread and fabric 4.Select the correct foot
Loose stitches	<ol style="list-style-type: none"> 1.The machine is not correctly threaded 2.The bobbin case is not correctly threaded 3.Needle/ fabric/ thread combination is wrong 4.Thread tension wrong 	<ol style="list-style-type: none"> 1.Check the threading 2.Thread the bobbin case as illustrated 3.The needle size must suit the fabric and thread 4.Correct the thread tension
Seams gather or pucker	<ol style="list-style-type: none"> 1.The needle is too thick for the fabric 2.The stitch length is wrongly adjusted 3.The thread tension is too tight 	<ol style="list-style-type: none"> 1.Select a finer needle 2.Readjust the stitch length 3.Loosen the thread tension
Uneven stitches, uneven feed	<ol style="list-style-type: none"> 1.Poor quality thread 2.The bobbin case is wrongly threaded 3.Fabric has been pulled 	<ol style="list-style-type: none"> 1.Select a better quality thread 2.Remove bobbin case and rethread and insert correctly 3.Do not pull on the fabric while sewing, let it be taken up by the machine
The machine is noisy	<ol style="list-style-type: none"> 1.The machine must be lubricated 2.Fluff or oil have collected on the hook or needle bar 3.Poor quality oil has been used 4.The needle is damaged 	<ol style="list-style-type: none"> 1.Lubricate as described 2.Clean the hook and feed dog as described 3.Only use good quality sewing machine oil 4.Replace the needle
The machine jams	Thread is caught in the hook	Remove the upper thread and bobbin case, turn the handwheel backwards and forwards by hand and remove the thread remnants. Lubricate as described

A

Accessories	18, 20
Adjust pattern balance	56
Adjusting the presser foot pressure	30
Applique	104
Attaching lace	102
Attaching the presser foot holder	32
Automatic needle threader	44

B

Blind hem/lingerie stitch	72
Bringing up the lower thread	48

C

Congratulations	12
Connecting machine to power source	26, 28
Cording foot	92

D

Darning	100
Decorative stitches	98

F

Free motion darning	94
---------------------	----

G

Gathering	116
-----------	-----

H

Hemmer foot	84
How to choose your pattern	62
How to drop feed dog	52
How to sew buttonholes	78, 80

I

Important safety instructions	1, 2
Inserting bobbin	36
Inserting the needle	40
Invisible zipper foot	114

L

Light bulb replacement	126
------------------------	-----

M

Maintenance	122, 124
Monogramming and embroidering with embroidery hoop	108

N

Needle up/down	54
Needle, fabric, thread selection	58

O

Overlock stitches	74
Overview	14, 16

P

Practical stitches	96
--------------------	----

Q

Quick reference drawer	24
Quilt stitch	110
Quilting	112

S

Securing a seam	50
Sewing on buttons	76
Sewing table	22, 24
Smocking stitch	90

Speed limiting adjustment	54
Start Stop Button	54
Stitch selection	88
Straight stitching and needle position	64, 66

T

Threading the bobbin thread	38
Threading the upper thread	42
Troubleshooting guide	128
Twin needle	106
Two-step presser foot lever	30

U

Upper thread tension	46
----------------------	----

W

Walking foot	118, 120
Winding the bobbin	34

Z

Zigzag stitching	68, 70
Zippers and piping	82
3-step zig-zag	86